

With Pitch Frame
INSTALLATION INSTRUCTIONS
FOR THERMOSIPHON SOLAR WATER HEATER SYSTEMS



*This frame must be installed by a qualified person.
Please leave this guide with the householder.*

SOLAHART INDUSTRIES PTY LTD – ABN 45 064 945 848 – 112 Pilbara Street Welshpool WA 6106 Australia
RHEEM AUSTRALIA PTY LTD – ABN 21 098 823 511 - 1 Alan Street (PO Box 6) Rydalmere NSW 2116 Australia
SOLAR EDWARDS – 112 Pilbara Street Welshpool WA 6106 Australia

PATENTS

This With Pitch frame may be protected by one or more patents or registered designs in the name of Solahart Industries Pty Ltd or Rheem Australia Pty Ltd.

TRADE MARKS

® Registered trademark of Solahart Industries Pty Ltd or Rheem Australia Pty Ltd.
™ Trademark of Solahart Industries Pty Ltd or Rheem Australia Pty Ltd.

Note: Every care has been taken to ensure accuracy in preparation of this publication.
No liability can be accepted for any consequences, which may arise as a result of its application.

CONTENTS

HOUSEHOLDER – This installation instruction booklet is intended for the installer but you may find it of interest.

About The With Pitch Frame	4
Tank Base Designs	9
Assembly Diagrams	10
Dimension Drawings.....	23
On Roof Mounting	25
Installation of Collector / Tank Rails	29
Installation of Tank and Solar Collectors	31
System Certifications.....	34

ABOUT THE WITH PITCH FRAME

MODEL TYPE

The With Pitch frame system is designed for pitched roof installations of thermosiphon solar water heaters. This installation instruction covers the installation of frames, using the “On Roof Mounting” method, suitable for thermosiphon systems with one to four collectors.

There are two main frame mounting systems. A ‘one collector frame’ is suitable for a tank and one collector installation and a ‘two collector frame’ is suitable for a tank and two collector installation. If a water heater system has three collectors, then a ‘one collector frame’ and a ‘two collector frame’ are required. If a water heater system has four collectors, then two ‘two collector frames’ are required.

On Roof Mounting

The “On Roof Mounting” method is not suitable for tile, slate, shingle and similar roof types.

Wind Region D Rating

The frame, when installed using the “On Roof Mounting” connection method and either Tek screw fixings into hardwood battens or M8 bolts with nut and washer fixings to steel battens, is rated to:

Wind Region	D	Terrain category	TC2	Wind Class *
Ultimate wind speed	88 m/s	Height (Hz)	10 m	N6 / C4

* Wind Class has been assessed in accordance with AS 4055-2006 ‘Wind loads for housing’.

LOCATION

The installation of a thermosiphon solar water heater on this frame (where the “On Roof Mounting” method is used), subject to its design criteria and certification not being exceeded:

- is suitable for installation in geographic locations up to and within Wind Region D as defined in the Building Code of Australia, Australian Standard AS 4055-2012 and the Australian / New Zealand Standard AS/NZS 1170.2:2011, and
- provides an acceptable method of installation where it is necessary to satisfy the requirements of the Building Code of Australia for high wind areas, or equivalent requirements.

Refer to “System Certifications” on page 34 for information on the certification of each system.

Refer to the Installation Instructions and Owner’s Guide supplied with the solar water heater in order to determine the most suitable direction for facing the system. Choose a mounting location, with direction in mind, that will also allow the frame to be centrally located over at least either two rafters (one collector frame) or three rafters (two collector frame) and provide the base plate sub-assemblies with suitable fixing access to the roof battens.

The installer must ensure the structural integrity of the building is not compromised by the solar water heater and frame installation and the roof structure is suitable to carry the full weight of the solar storage tank, solar collector(s) and frame. If in doubt, consult a structural engineer, who may specify suitable strengthening of the roof structure.

IMPORTANT NOTES, GENERAL DESIGN CRITERIA AND LIMITATIONS

- The roof pitch angle is not to be less than 10° nor exceed 45°.
- Trusses and rafters spacing is not to exceed 1200 mm centres.
- The frame is not rated for installation on a free roof or canopy as defined in AS 1170.2:2011 Appendix A.
- The roof construction should be verified to ensure that it can support the additional loads imposed by the installation of the solar collectors and the frame.
- The roof battens are to be continuous over not less than three rafters or trusses for either a one or two collector frame.
- The certifications of the frames cover their installation in Australia.
- The installation shall be in accordance with these installation instructions.
- The installer is to provide the fixings for the frame to the roof. Fixings are to be in accordance with the methods and drawings outlined in these installation instructions.

SOLAR WATER HEATER SYSTEMS

The With Pitch frame system is suitable for installation with the thermosiphon systems listed below, including rebranded systems using the same tank designs. The table lists the kits and the quantity required for each thermosiphon system.

	Sales BOM and additional kits ordered	Kits supplied for frame system					
		1210 6910	1210 6911	1210 6912	1210 3998	1210 3999	1210 4000
Edwards Thermosiphon Systems – SS Tank							
L180, LX180 tank – one collector	1 x 340317	1	1	-	1	-	-
L180, LX180 tank – two collectors	1 x 340306 + 1 x 12103998	2	-	1	1	-	-
L305, LX305 tank – two collectors	1 x 340318	2	-	1	-	1	-
L305, LX305 tank – three collectors	1 x 340318 + 1 x 340305	3	1	1	-	1	-
L440, LX440 tank – three collectors	1 x 340305 + 1 x 340306 + 1 x 12104000	3	1	1	-	-	1
L440, LX440 tank – four collectors	2 x 340306 + 1 x 12104000	4	-	2	-	-	1
Rheem Thermosiphon Systems – VE Tank							
52S160 tank – one collector	1 x 340305	1	1	-	-	-	-
52S300 tank – two collectors	1 x 340306	2	-	1	-	-	-
Rheem Thermosiphon Systems – SS Tank							
52H180, 52L180 tank – one collector	1 x 340317	1	1	-	1	-	-
52H300, 52L300 tank – two collectors	1 x 340318	2	-	1	-	1	-
52H300 tank – three collectors	1 x 340318 + 1 x 340305	3	1	1	-	1	-
Solahart Thermosiphon Systems – VE Tank							
150F, 150J, 150L, 150LF tank – one collector 180F, 180J, 180L, 180LF tank – one collector 220F, 220J, 220L, 220LF tank – one collector	1 x 340305	1	1	-	-	-	-
180F, 180J, 180L, 180LF tank – two collectors 220F, 220J, 220L, 220LF tank – two collectors 300F, 300J, 300L, 300LF tank – two collectors	1 x 340306	2	-	1	-	-	-
300F, 300J, 300L, 300LF tank – three collectors 440F, 440J, 440L, 440LF tank – three collectors	1 x 340305 + 1 x 340306	3	1	1	-	-	-
440F, 440J, 440L, 440LF tank – four collectors	2 x 340306	4	-	2	-	-	-
Sunheat Thermosiphon Systems – VE Tank							
160D direct system tank – one collector 180C indirect system tank – one collector	1 x 340305	1	1	-	-	-	-
300D direct system tank – two collectors 300C indirect system tank – two collectors	1 x 340306	2	-	1	-	-	-

Note: SS = stainless steel tanks VE = vitreous enamel lined tanks

PARTS SUPPLIED

The kits that make up the With Pitch frame system contain the parts required, including tank clamps, collector clamps, screws, washers and nuts, for assembling the frame and attaching the solar storage tank and solar collectors to the frame.

The tank clamps, collector clamps, screws, washers and nuts supplied with the kits must be used with these frames. They replace the tank clamps, collector clamps, screws, washers and nuts that may be supplied in the parts kit or pipe kit supplied with the solar water heater, which must not be used with these frames.

Refer to “List of Components” on page 8.

Note: The kits do not include the hardware for mounting the frame to the roof.

TANK FRAME MOUNTING KIT

The Edwards L and LX and Rheem 52H and 52L solar stainless steel tanks require a tank frame mounting kit to be assembled to the flat base of these tanks. When assembled onto the tank, the reinforcement provides additional strength to the foot of the tank (refer to the diagram “Solar Storage Tank with Flat Base and Reinforcement Plates” on page 9).

The kit part numbers are:

- 12103998 Tank Frame Mounting Kit L180, LX180, 52H180, 52L180
- 12103999 Tank Frame Mounting Kit L305, LX305, 52H300, 52L300
- 12104000 Tank Frame Mounting Kit L440, LX440

ONE AND TWO COLLECTOR INSTALLATIONS

The frame systems and the kits required are:

- **340305** **Frame With Pitch 1 Collector Thermosiphon VE Cat D**, consisting of
 - 1 x 12106910 Kit With Pitch Frame U Channels Thermo Reg D
 - 1 x 12106911 Kit With Pitch Frame Base 1 Collector Thermo Reg D
- **340306** **Frame With Pitch 2 Collector Thermosiphon VE Cat D**, consisting of
 - 2 x 12106910 Kit With Pitch Frame U Channels Thermo Reg D
 - 1 x 12106912 Kit With Pitch Frame Base 2 Collector Thermo Reg D
- **340317** **Frame With Pitch 1 Collector Thermosiphon SS Cat D (180 tank)**, consisting of
 - 1 x 12106910 Kit With Pitch Frame U Channels Thermo Reg D
 - 1 x 12106911 Kit With Pitch Frame Base 1 Collector Thermo Reg D
 - 1 x 12103998 Kit Frame Mounting 180 SS Tank Reg D
- **340318** **Frame With Pitch 2 Collector Thermosiphon SS Cat D (300/305 tank)**, consisting of
 - 2 x 12106910 Kit With Pitch Frame U Channels Thermo Reg D
 - 1 x 12106912 Kit With Pitch Frame Base 2 Collector Thermo Reg D
 - 1 x 12103999 Kit Frame Mounting 300 / 305 SS Tank Reg D

An installation of a 180 stainless steel thermosiphon system with two collectors requires the following kits:

180 Stainless Steel Tank with Two Collectors

- 1 x 340306 Frame With Pitch 2 Collector Thermosiphon VE Cat D
- 1 x 12103998 Kit Frame Mounting 180 SS Tank Reg D

These consist of:

- 2 x 12106910 Kit With Pitch Frame U Channels Thermo Reg D
- 1 x 12106912 Kit With Pitch Frame Base 2 Collector Thermo Reg D
- 1 x 12103998 Kit Frame Mounting 180 SS Tank Reg D

THREE AND FOUR COLLECTOR INSTALLATIONS

Installations of thermosiphon systems with three and four collectors require the following kits:

300, 440 Vitreous Enamel Tanks with Three Collectors

- 1 x 340305 Frame With Pitch 1 Collector Thermosiphon VE Cat D, and
- 1 x 340306 Frame With Pitch 2 Collector Thermosiphon VE Cat D

These consist of:

- 3 x 12106910 Kit With Pitch Frame U Channels Thermo Reg D
- 1 x 12106911 Kit With Pitch Frame Base 1 Collector Thermo Reg D
- 1 x 12106912 Kit With Pitch Frame Base 2 Collector Thermo Reg D

300, 440 Vitreous Enamel Tanks with Four Collectors

- 2 x 340306 Frame With Pitch 2 Collector Thermosiphon VE Cat D

These consist of:

- 4 x 12106910 Kit With Pitch Frame U Channels Thermo Reg D
- 2 x 12106912 Kit With Pitch Frame Base 2 Collector Thermo Reg D

300 / 305 Stainless Steel Tank with Three Collectors

- 1 x 340318 Frame With Pitch 2 Collector Thermosiphon SS Cat D, and
- 1 x 340305 Frame With Pitch 1 Collector Thermosiphon VE Cat D

These consist of:

- 3 x 12106910 Kit With Pitch Frame U Channels Thermo Reg D
- 1 x 12106911 Kit With Pitch Frame Base 1 Collector Thermo Reg D
- 1 x 12106912 Kit With Pitch Frame Base 2 Collector Thermo Reg D
- 1 x 12103999 Kit Frame Mounting 300 / 305 SS Tank Reg D

440 Stainless Steel Tank with Three Collectors

- 1 x 340305 Frame With Pitch 1 Collector Thermosiphon VE Cat D, and
- 1 x 340306 Frame With Pitch 2 Collector Thermosiphon VE Cat D, and
- 1 x 12104000 Kit Frame Mounting 440 SS Tank Reg D

These consist of:

- 3 x 12106910 Kit With Pitch Frame U Channels Thermo Reg D
- 1 x 12106911 Kit With Pitch Frame Base 1 Collector Thermo Reg D
- 1 x 12106912 Kit With Pitch Frame Base 2 Collector Thermo Reg D
- 1 x 12104000 Kit Frame Mounting 440 SS Tank Reg D

440 Stainless Steel Tanks with Four Collectors

- 2 x 340306 Frame With Pitch 2 Collector Thermosiphon VE Cat D, and
- 1 x 12104000 Kit Frame Mounting 440 SS Tank Reg D

These consist of:

- 4 x 12106910 Kit With Pitch Frame U Channels Thermo Reg D
- 2 x 12106912 Kit With Pitch Frame Base 2 Collector Thermo Reg D
- 1 x 12104000 Kit Frame Mounting 440 SS Tank Reg D

LIST OF COMPONENTS

The contents of the With Pitch Frame U channel kit for all model tanks are:

Component Part No	12106910 Kit With Pitch Frame U Channels Thermo Reg D Component Description	Quantity
342558	Cyclone U frame – slotted	2

The contents of the With Pitch Frame base kits for all model tanks are:

Component Part No	Kit With Pitch Frame Base Thermo Reg D Component Description	Kit 12106911 1 Collector	Kit 12106912 2 Collector
341562	Base plate sub-assembly 1 collector system	2	-
341564	Base plate sub-assembly 2 collector system	-	2
344671	Collector rail extra heavy duty (T6) 1 collector frame	1	-
344672	Collector rail extra heavy duty (T6) 2 collector frame	-	1
344677	Tank / collector rail extra heavy duty (T6) 1 collector frame	1	-
344678	Tank / collector rail extra heavy duty (T6) 2 collector frame	-	1
	Contents of polyethylene bag	1	1
348033	Set screw hex 5/16" UNC x 1 1/2" SS	14	22
348032	Washer round Ø 30 mm x 8 mm SS	10	18
348034	Washer square 50 x 50 x 8 mm SS	2	4
348036	Washer rectangular 35 x 19 x 8 mm SS	4	8
330354	Washer 5/16" SS	6	6
330806	Nut 5/16" SS	10	16
080071	Screw Tek No. 14 x 20	2	2
348042	Screw socket head cap 5/16" UNC x 3/4" SS	-	2
344120	Collector clamp Cat D cyclone (aluminium)	2	4
344121	Tank clamp Cat D cyclone (aluminium)	2	2
343038	Tank clamp Rheem (tank clamp round tank – galvanised steel)	2	2
347597	Installation instructions – With Pitch frame thermosiphon	1	1

The contents of the frame mounting kits for the stainless steel tanks are:

Component Part No	Kit Frame Mounting SS Tanks Reg D Component Description	Kit 12103998 180 SS Tank	Kit 12103999 305 SS Tank	Kit 12104000 440 SS Tank
343060	Tank Strap Long Cyclone	2	2	2
343238	Front Reinforcement Plate 180 SS Tank	1	-	-
343240	Front Reinforcement Plate 300 / 305 SS Tank	-	1	-
343242	Front Reinforcement Plate 440 SS Tank	-	-	1
343239	Rear Reinforcement Angle 180 SS Tank	1	-	-
343241	Rear Reinforcement Angle 300 / 305 SS Tank	-	1	-
343243	Rear Reinforcement Angle 440 SS Tank	-	-	1
	Contents of polyethylene bag	1	1	1
343203	Tank Strap Rear Bracket	2	2	2
343207	Tank Clamp SS Tank – Galvanised Steel	2	2	2
080167	Screw Tek 10 G x 16 mm	11	14	14
348033	Set Screw Hex 5/16" UNC x 1 1/2" SS	2	2	2
330806	Nut 5/16" SS	2	2	2
347667	Installation instructions – SS Tank Frame Mounting	1	1	1

Note: The kits do not include the hardware for mounting the frame to the roof.

TANK BASE DESIGNS

References are made in these installation instructions relating to the type of tank base and supporting feet design and how it is fixed to the With Pitch frame. Each design of tank base and feet has its own unique method of connecting to the frame.

The types of tank base design and supporting feet are:

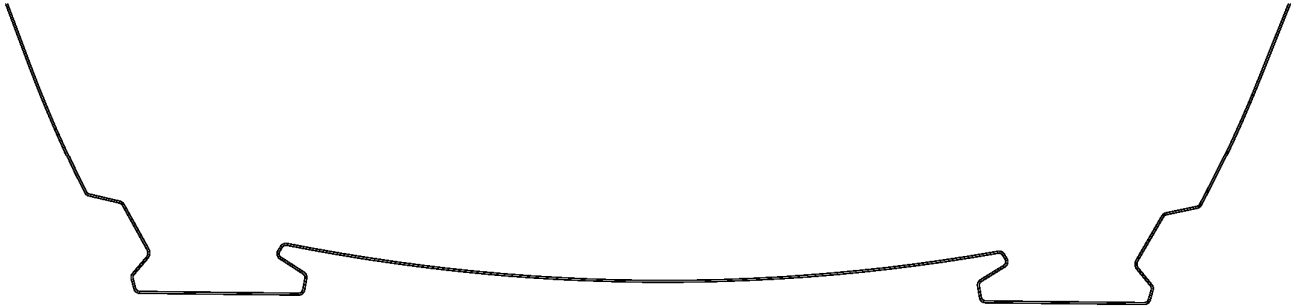

**Solar Storage Tank with Two Flat Feet
(Solahart tanks and Sunheat closed circuit 'C' tanks)**



**Solar Storage Tank with Z-section Feet
(Rheem Hiline 52S tanks and Sunheat direct 'D' tanks)**

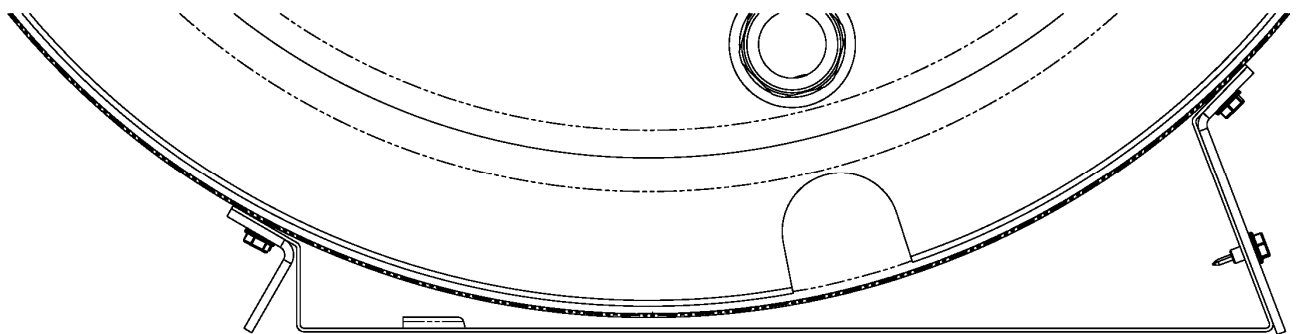

**Solar Storage Tank with Flat Base and Reinforcement Plates
(Edwards L and LX tanks and Rheem 52H and 52L tanks)**

ASSEMBLY DIAGRAMS

SOLAR STORAGE TANK WITH TWO FLAT FEET – FRAME ASSEMBLY

Solahart Thermosiphon Systems

150F, 150J, 150L, 150LF tank with one collector
 180F, 180J, 180L, 180LF tank with one collector
 220F, 220J, 220L, 220LF tank with one collector

Sunheat Thermosiphon Systems

180C indirect system tank with one collector

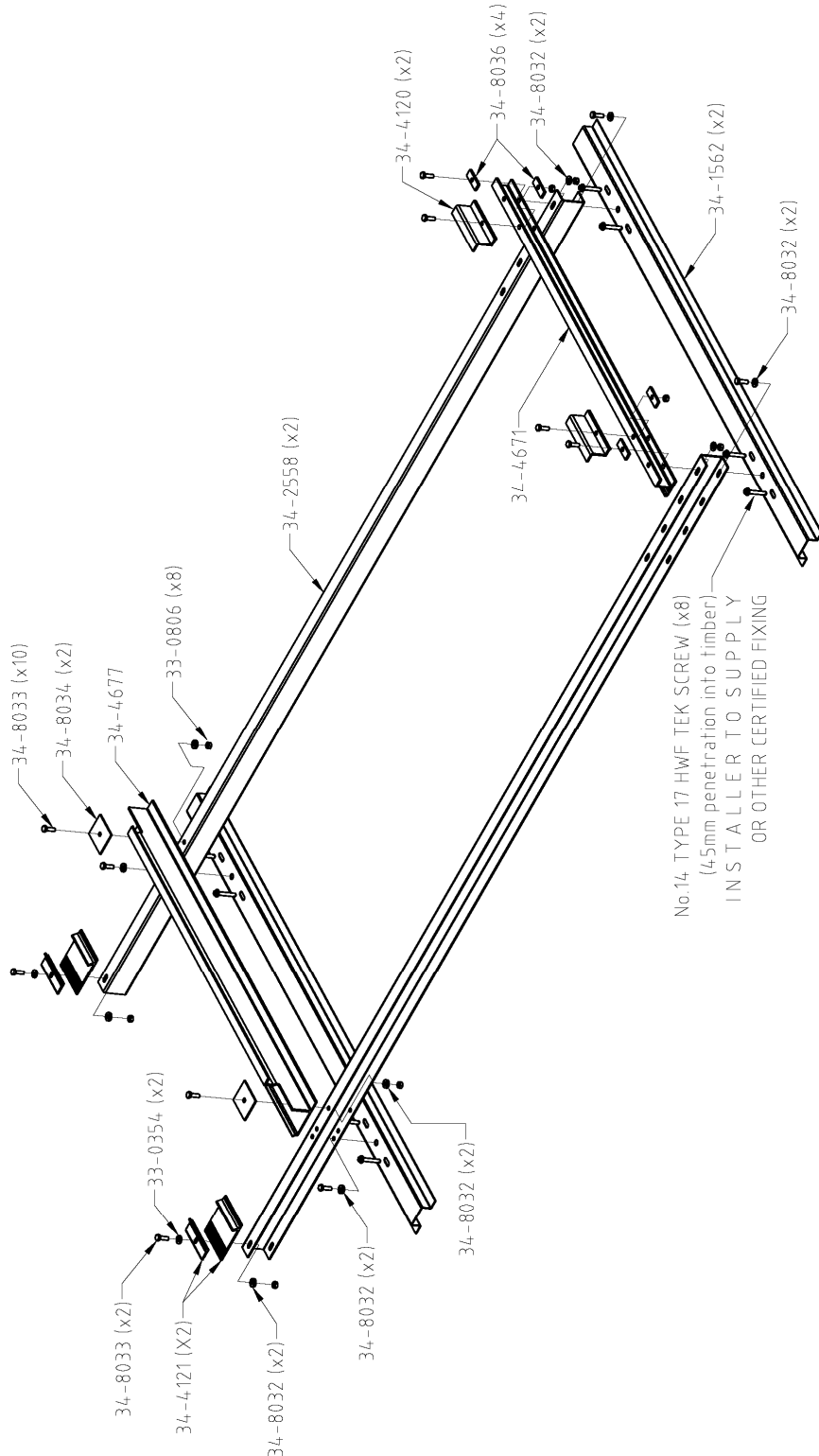

Diagram 1
Thermosiphon 150, 180, 220 VE Tank One Collector Systems – 1 x 340305

Solahart Thermosiphon Systems

180F, 180J, 180L, 180LF tank with two collectors

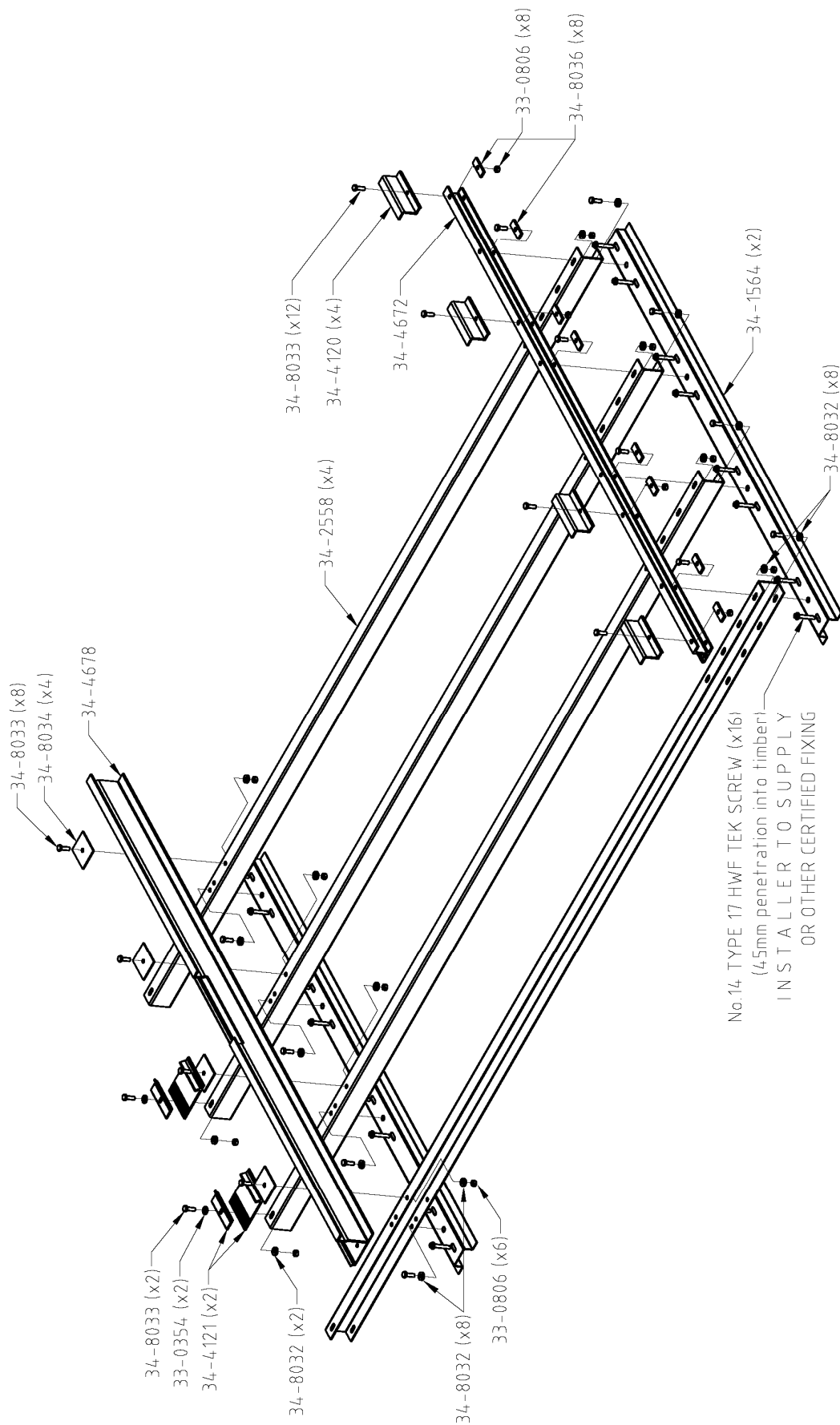

Diagram 2
Thermosiphon 180 VE Tank Two Collector Systems – 1 x 340306

Solahart Thermosiphon Systems

220F, 220J, 220L, 220LF tank with two collectors
 300F, 300J, 300L, 300LF tank with two collectors

Sunheat Thermosiphon Systems

300C indirect system tank with two collectors

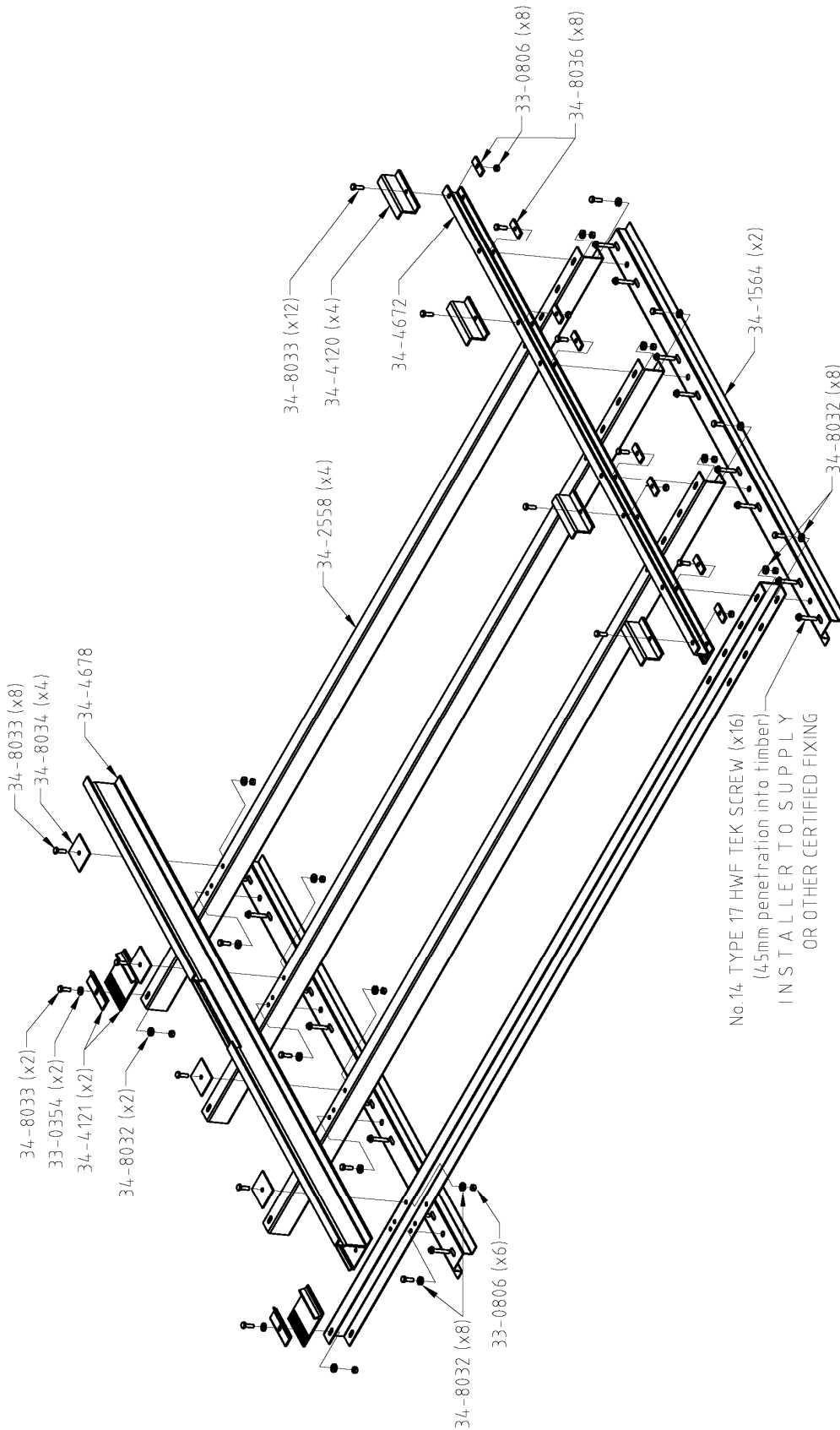

Diagram 3
Thermosiphon 220, 300 VE Tank Two Collector Systems – 1 x 340306

Solahart Thermosiphon Systems

300F, 300J, 300L, 300LF tank with three collectors

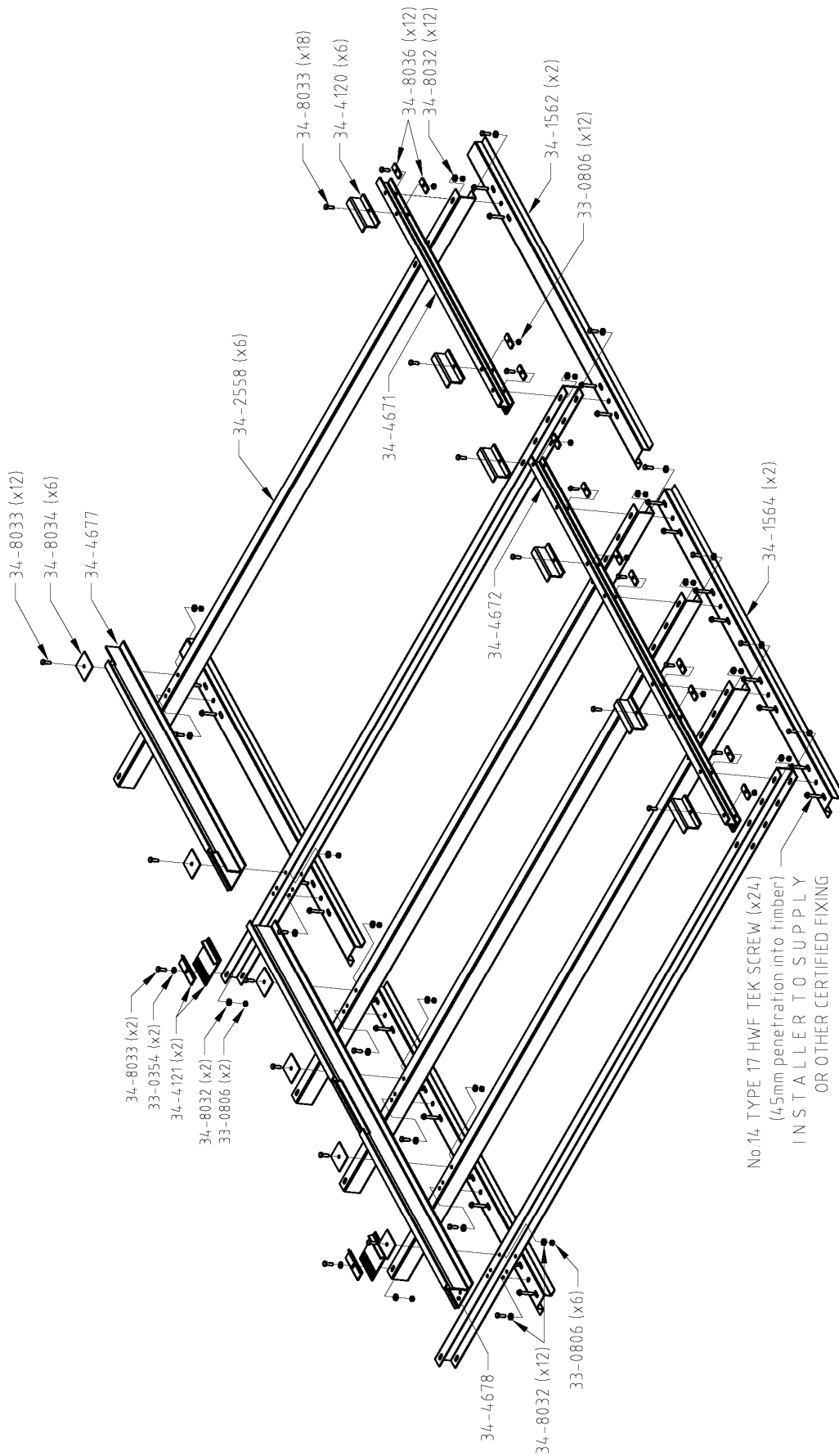

Diagram 4
Thermosiphon 300 VE Tank Three Collector Systems – 1 x 340305 + 1 x 340306

Solahart Thermosiphon Systems

440F, 440J, 440L, 440LF tank with three collectors

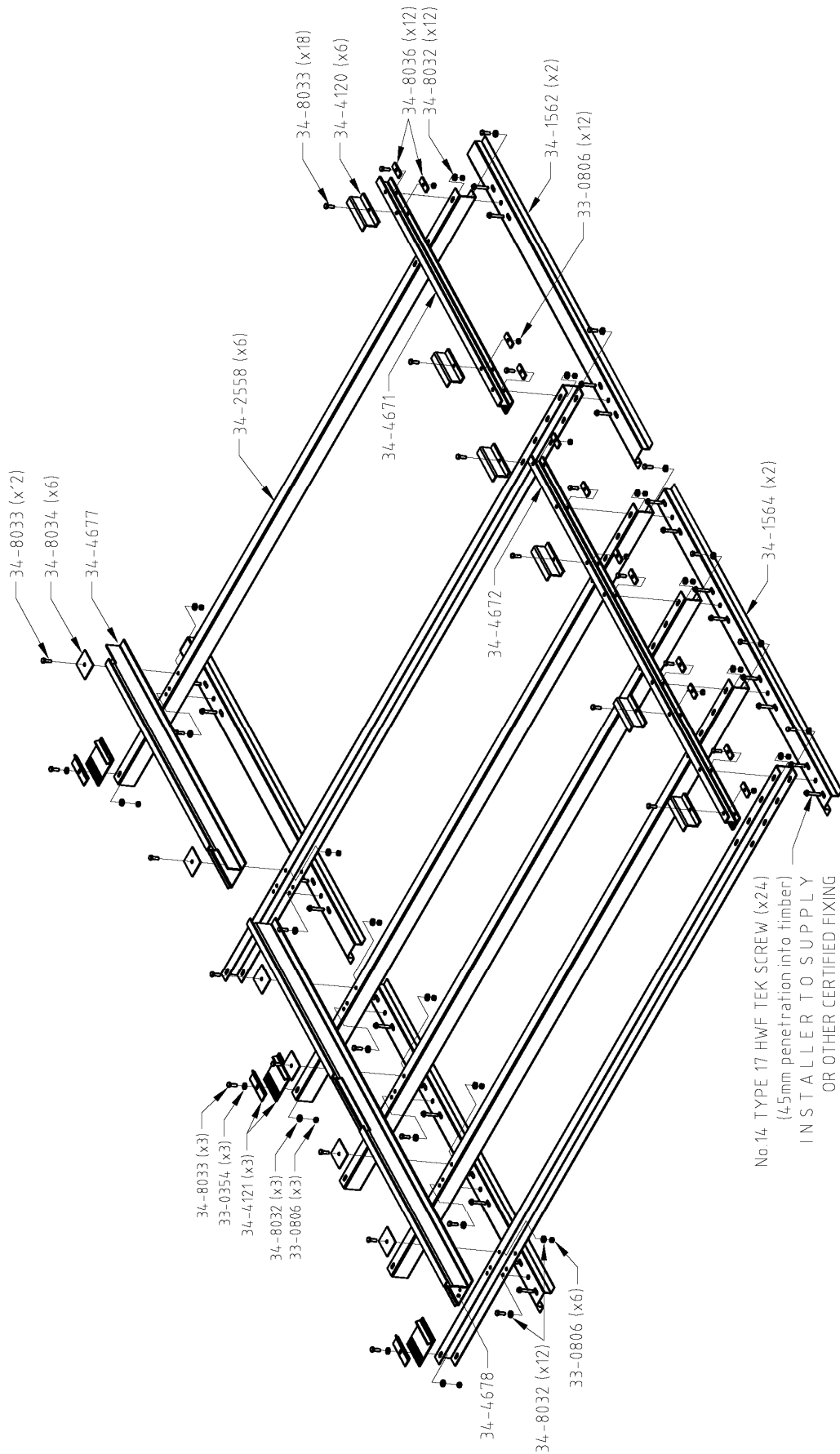

Diagram 5
Thermosiphon 440 VE Tank Three Collector Systems – 1 x 340305 + 1 x 340306

Solahart Thermosiphon Systems

440F, 440J, 440L, 440LF tank with four collectors

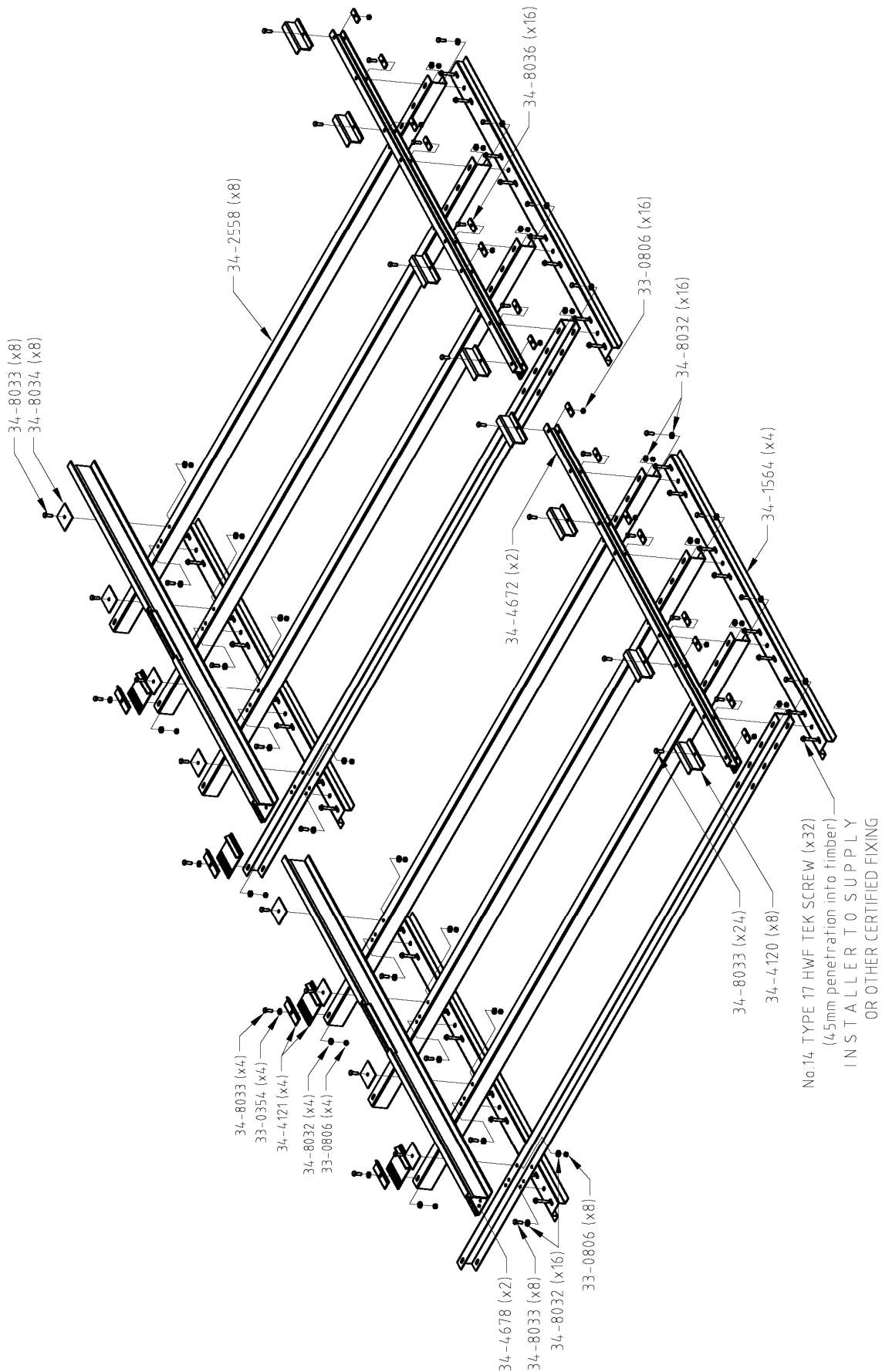

Diagram 6
Thermosiphon 440 VE Tank Four Collector Systems – 2 x 340306

SOLAR STORAGE TANK WITH Z-SECTION FEET – FRAME ASSEMBLY

Rheem Thermosiphon Systems

52S160 tank with one collector

Sunheat Thermosiphon Systems

160D direct system tank with one collector

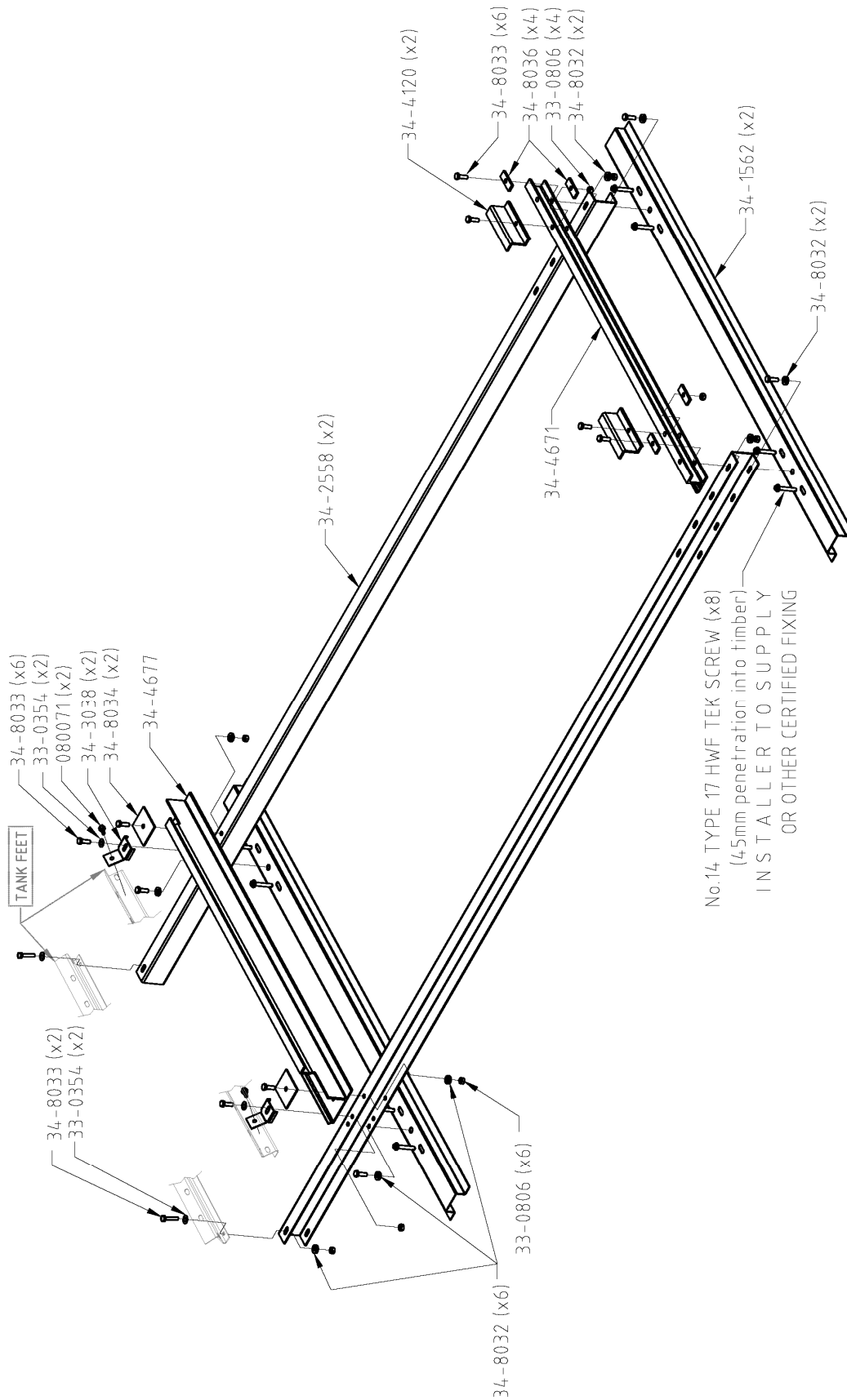

Diagram 7
Thermosiphon 160 VE Tank One Collector Systems – 1 x 340305

Rheem Thermosiphon Systems

52S300 tank with two collectors

Sunheat Thermosiphon Systems

300D direct system tank with two collectors

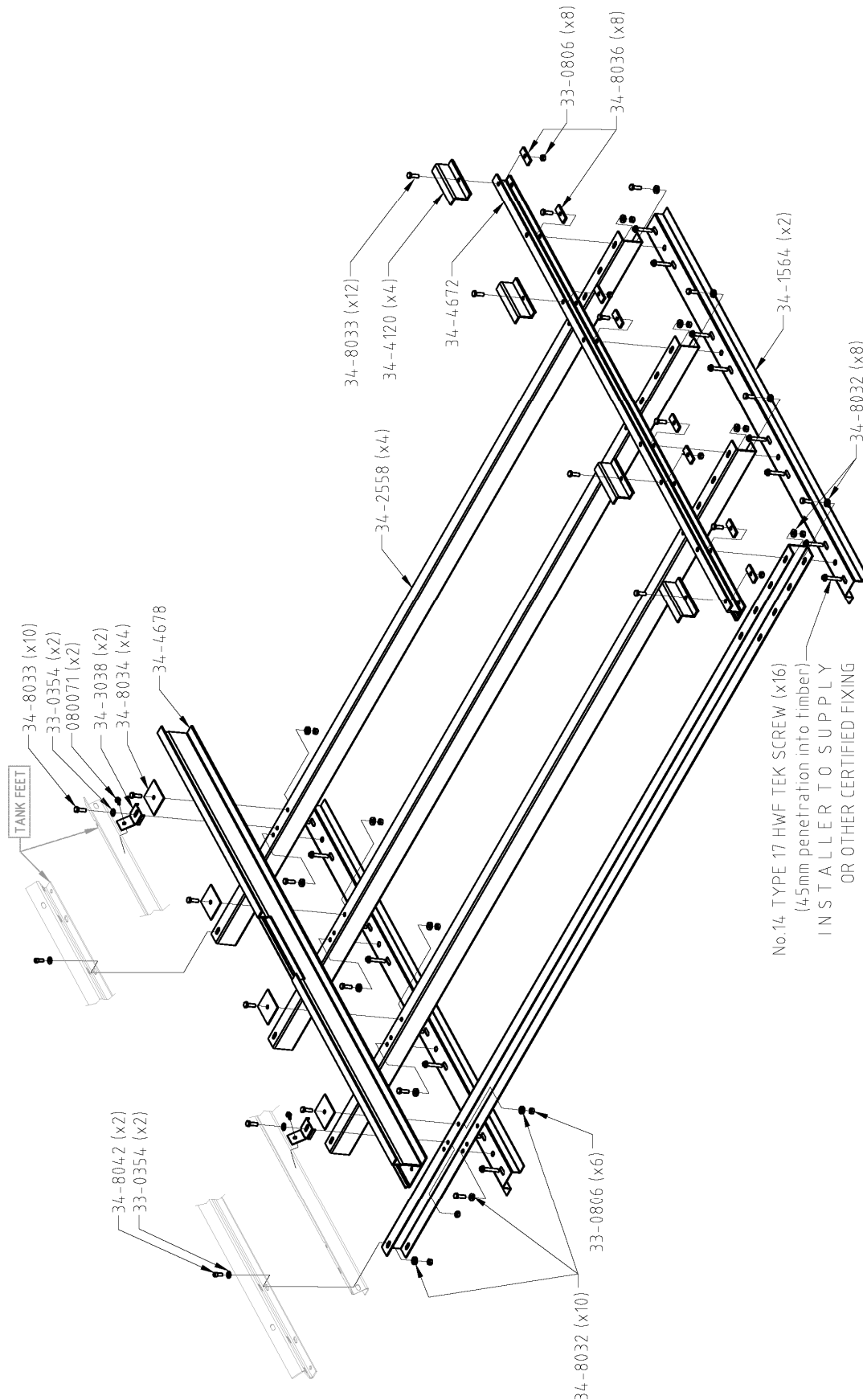

Diagram 8
Thermosiphon 300 VE Tank Two Collector Systems – 1 x 340306

SOLAR STORAGE TANK WITH FLAT BASE – FRAME ASSEMBLY

Edwards Thermosiphon Systems

L180, LX180 tank with one collector

Rheem Thermosiphon Systems

52H180, 52L180 tank with one collector

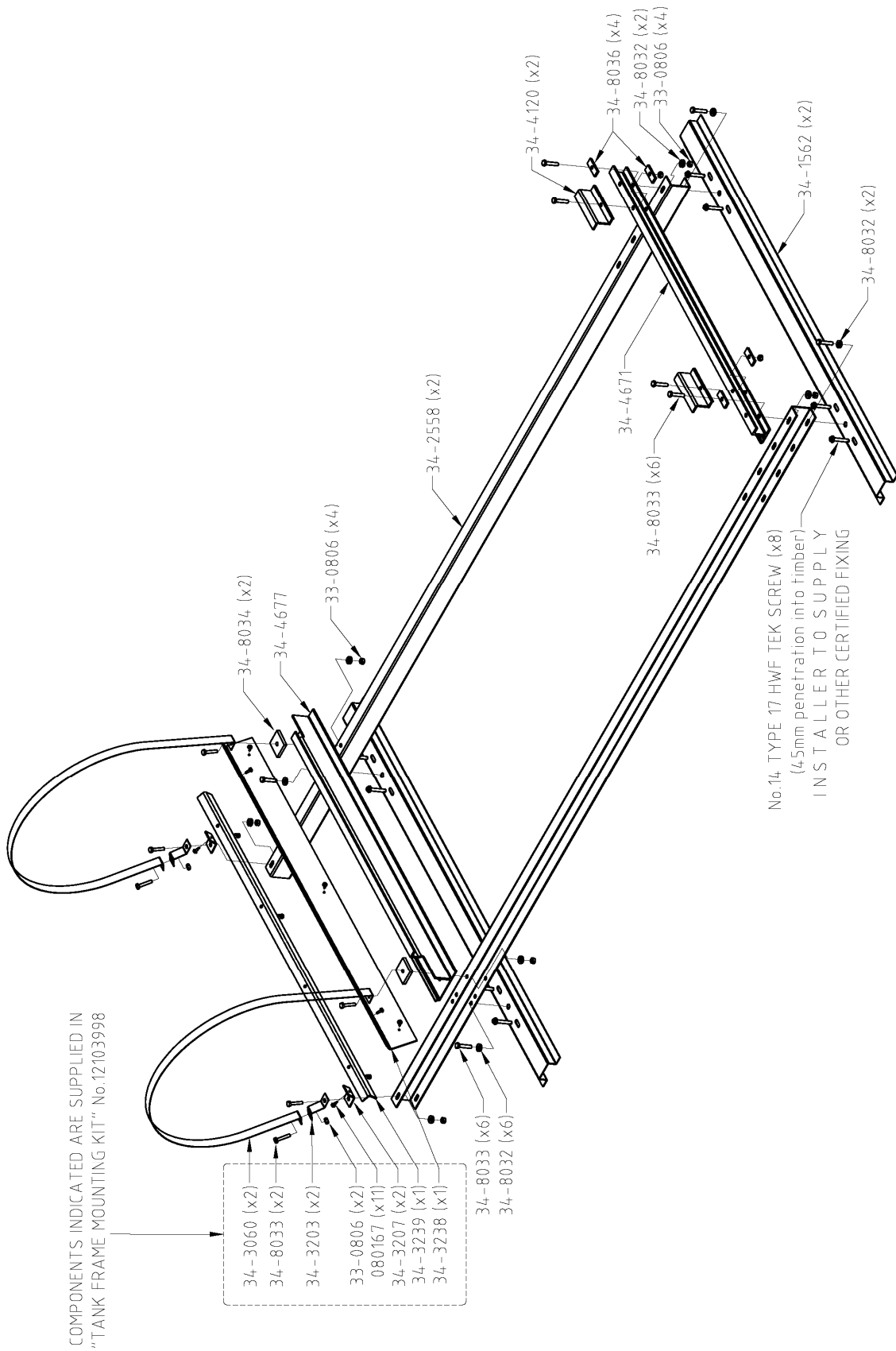

Diagram 9
Thermosiphon 180 SS Tank One Collector Systems – 1 x 340317

Edwards Thermosiphon Systems

L180, LX180 tank with two collectors

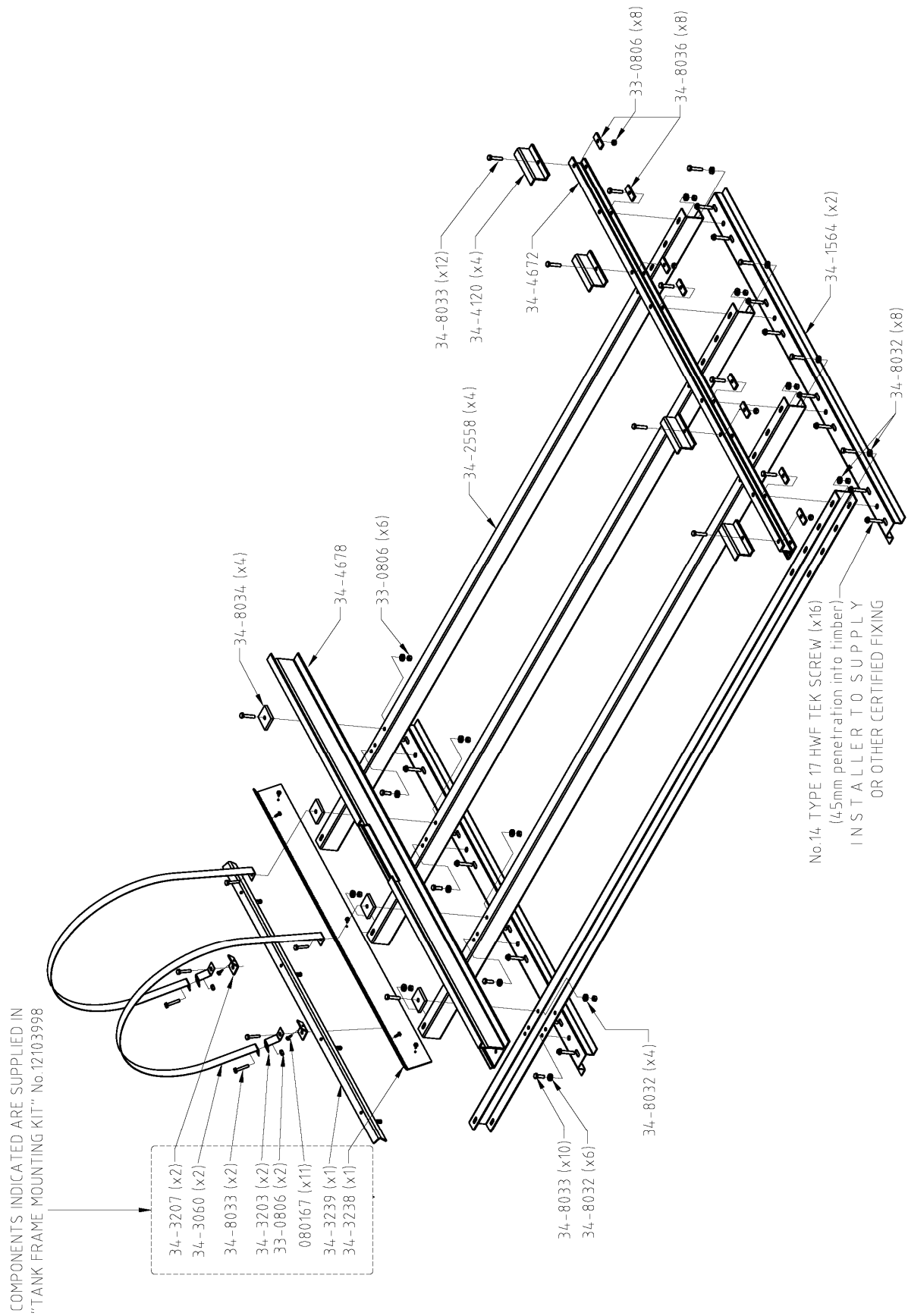

Diagram 10
Thermosiphon 180 SS Tank Two Collector Systems – 1 x 340306 + 1 x 12103998

Edwards Thermosiphon Systems
L305, LX305 tank with two collectors

Rheem Thermosiphon Systems
52H300, 52L300 tank with two collectors

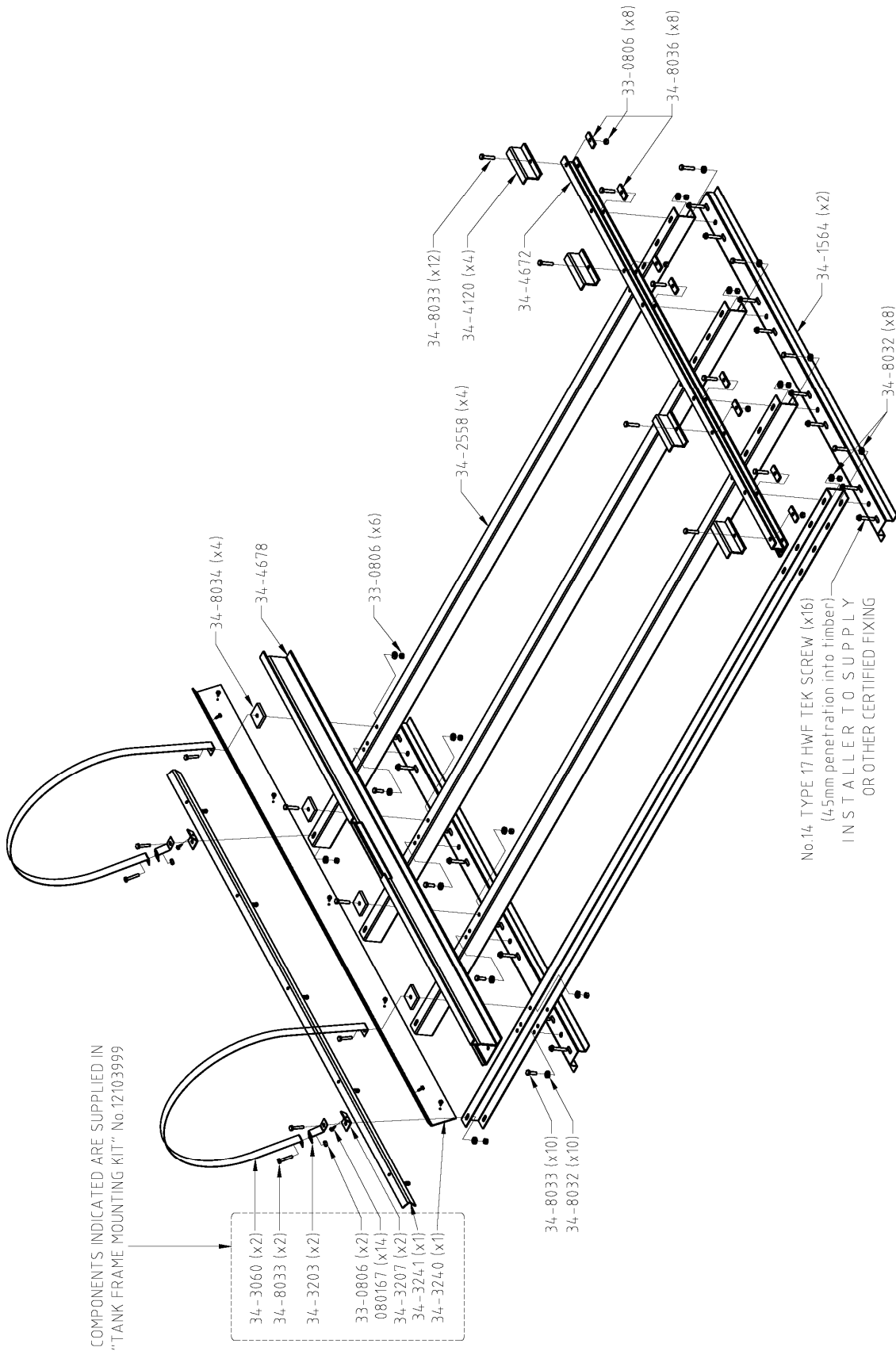

Diagram 11
Thermosiphon 300, 305 SS Tank Two Collector Systems – 1 x 340318

Edwards Thermosiphon Systems

L305, LX305 tank with three collectors
(1 x 340318 + 1 x 340305)

L440, LX440 tank with three collectors
(1 x 340305 + 1 x 340306 + 1 x 12104000)

Rheem Thermosiphon Systems

52H300 tank with three collectors
(1 x 340318 + 1 x 340305)

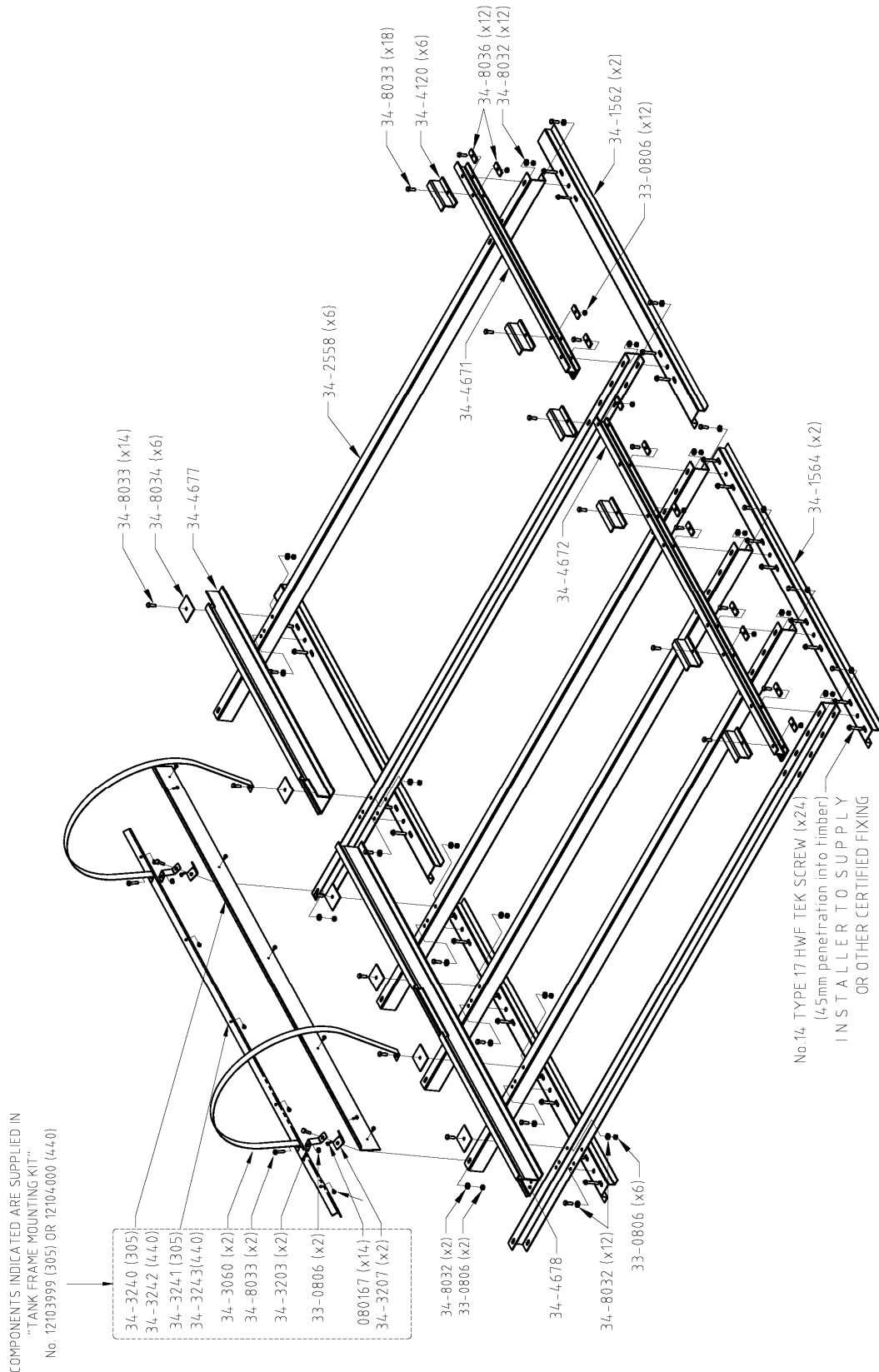

Diagram 12
Thermosiphon 300, 305, 440 SS Tank Three Collector Systems

Edwards Thermosiphon Systems

L440, LX440 tank with four collectors

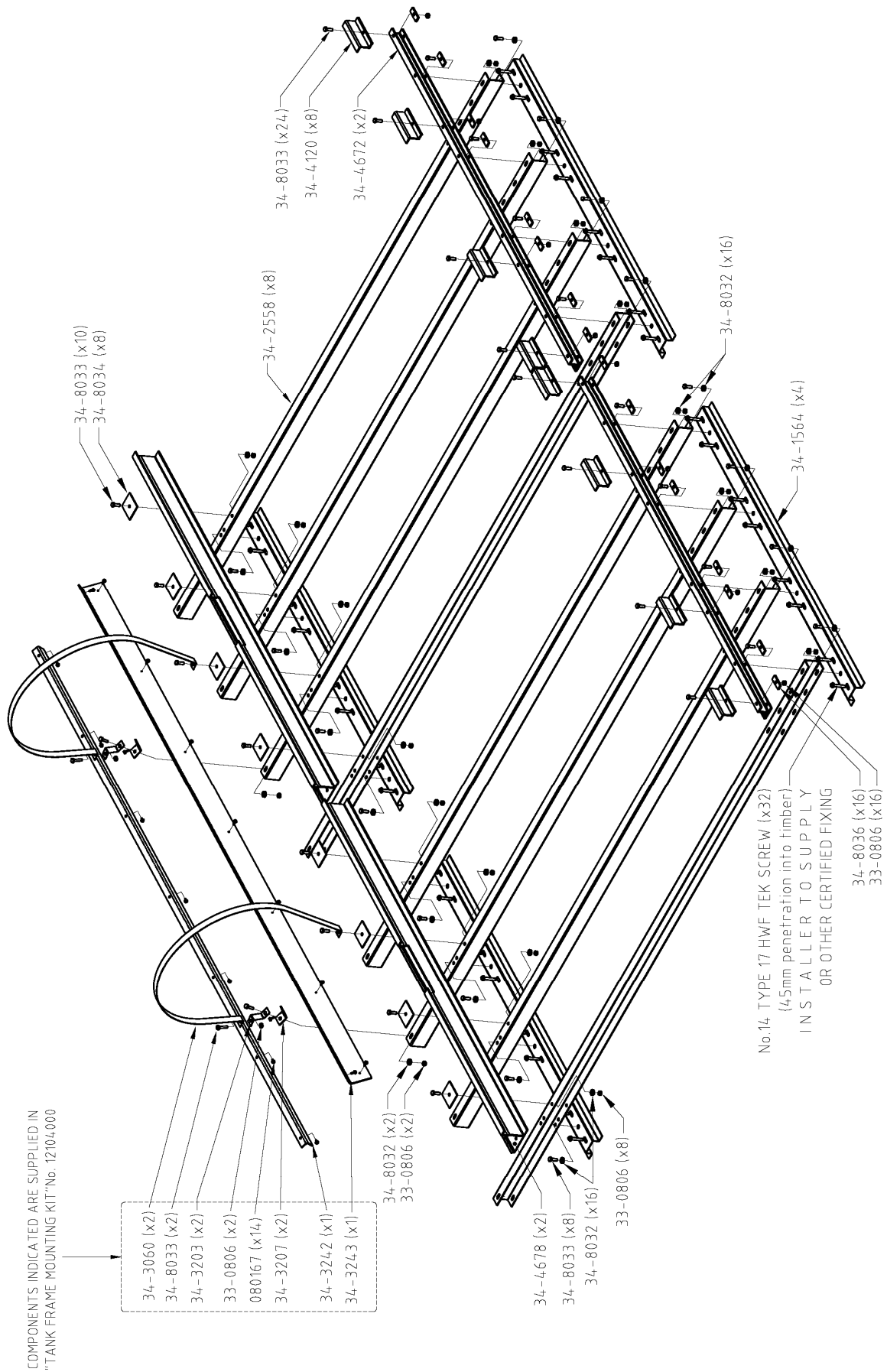
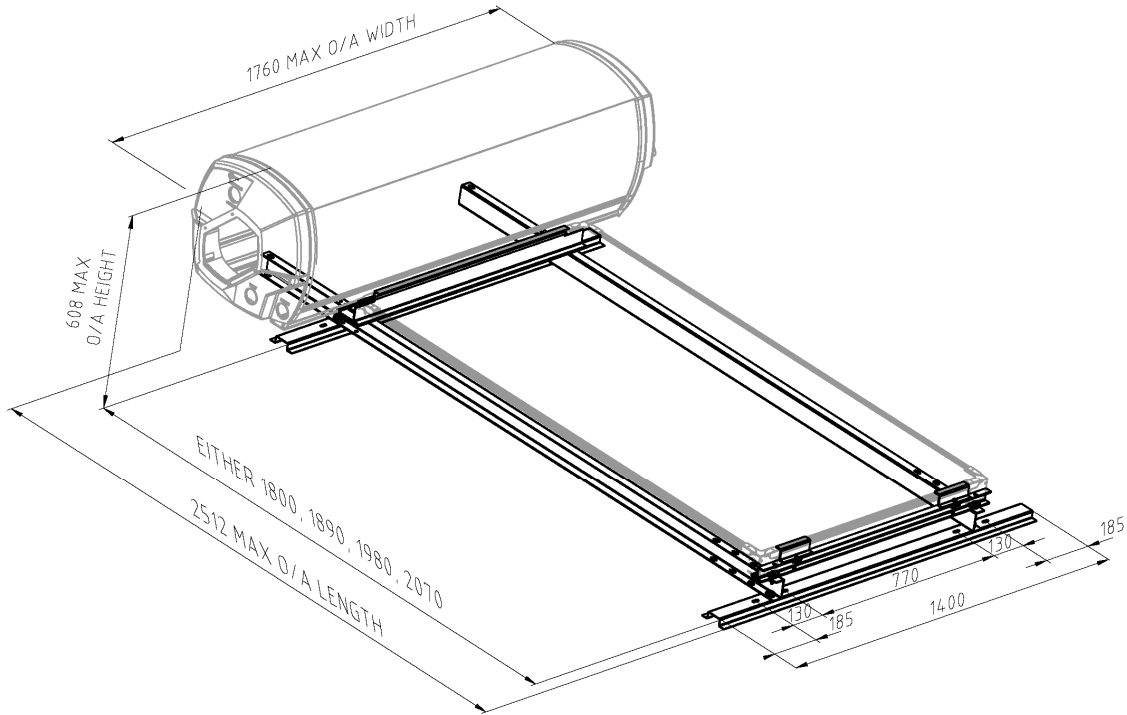

Diagram 13
Thermosiphon 440 SS Tank Four Collector System – 2 x 340306 + 1 x 12104000

DIMENSION DRAWINGS

Note: "MAX O/A" dimensions include tank / collector(s) / frame only. They exclude pipe work.



Thermosiphon One Collector – With Pitch Thermosiphon Frame

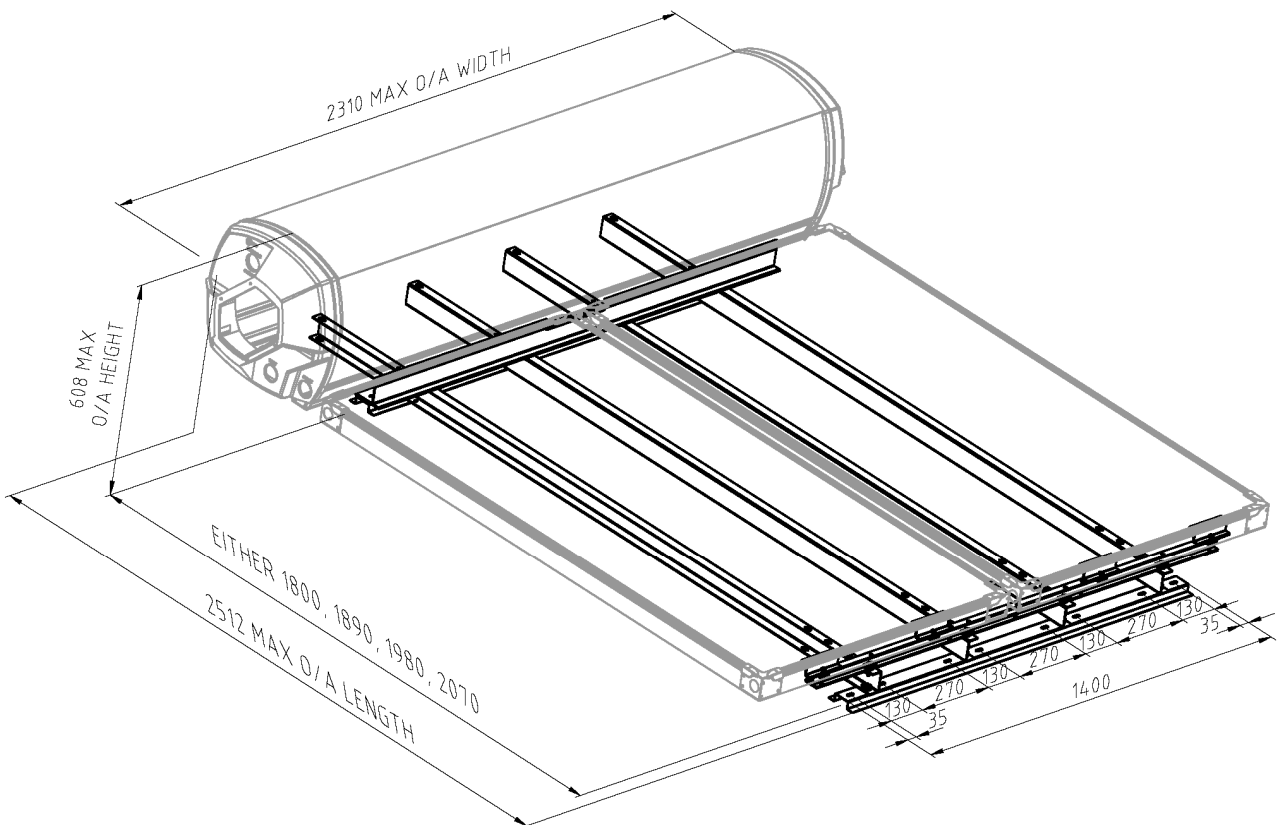

Thermosiphon Two Collector – With Pitch Thermosiphon Frame

ON ROOF MOUNTING

The “On Roof Mounting” method is not suitable for tile, slate, shingle and similar roof types.

Refer to the assembly diagrams;

- solar storage tanks with two flat feet
 - Solahart 150, 180 or 220 tanks with one collector – Diagram 1 on page 10.
 - Solahart 180 tanks with two collectors – Diagram 2 on page 11.
 - Solahart 220 or 300 tanks with two collectors – Diagram 3 on page 12.
 - Solahart 300 tanks with three collectors – Diagram 4 on page 13.
 - Solahart 440 litre tanks with three collectors – Diagram 5 on page 14.
 - Solahart 440 litre tanks with four collectors – Diagram 6 on page 15.
 - Sunheat ‘C’ 180 tank with one collector – Diagram 1 on page 10.
 - Sunheat ‘C’ 300 tank with two collectors – Diagram 3 on page 12.
- solar storage tanks with Z-section feet
 - Rheem 52S 160 tank with one collector – Diagram 7 on page 16.
 - Rheem 52S 300 tank with two collectors – Diagram 8 on page 17.
 - Sunheat ‘D’ 160 tank with one collector – Diagram 7 on page 16.
 - Sunheat ‘D’ 300 tank with two collectors – Diagram 8 on page 17.
- solar storage tanks with a flat base
 - Edwards ‘L’ and ‘LX’ 180 tanks with one collector – Diagram 9 on page 18.
 - Edwards ‘L’ and ‘LX’ 180 tanks with two collectors – Diagram 10 on page 19.
 - Edwards ‘L’ and ‘LX’ 305 tanks with two collectors – Diagram 11 on page 20.
 - Edwards ‘L’ and ‘LX’ 305 or 440 tanks with three collectors – Diagram 12 on page 21.
 - Edwards ‘L’ and ‘LX’ 440 tanks with four collectors – Diagram 13 on page 22.
 - Rheem 52H and 52L 180 tanks with one collector – Diagram 9 on page 18.
 - Rheem 52H and 52L 300 tanks with two collectors – Diagram 11 on page 20.

Notes:

- All screws and nuts referenced in the assembly instructions are a hex set screw 5/16” UNC x 1½” SS (348033) and a 5/16” UNC SS nut (330806) supplied in the kit unless otherwise specified.
- Penetrations through the roofing material must be:
 - at the high point of the roof or metal sheet profile;
 - made neatly and kept as small as practicable;
 - waterproofed upon installation of the Tek screws or bolts.
- Care should be taken not to mark Colorbond or other metal roof sheet with a marking pen and to remove all swarf from the metal roof as these can cause deterioration of the metal roofing material.

To assemble the With Pitch frame and install on the roof:

- Determine the position on the roof where the frame and solar water heater is to be installed.
 - The frame is required to be fixed to two roof battens.
 - The centre to centre distance between the two roof battens is to be either 1800 mm, 1890 mm, 1980 mm or 2070 mm. Check this distance with the distance between the two holes on a U-frame which are to be used to secure the base plates to the U-frames and ensure the distances are equal.
 - The roof battens are to be securely fixed to each rafter or truss. They may be of either:
 - ❖ a minimum 75 mm x 50 mm hardwood timber, or
 - ❖ a minimum 0.75 BMT G550 steel.
 - The roof battens are to be continuous over not less than three rafters or trusses for either a one collector frame or a two collector frame.
 - If new battens are required, select the position of and install the two roof battens to which the With Pitch frame is to be fixed.
- Loosely fit the base plates and the U-frames together, using screws and washers provided, securing a screw into each nutsert in the base plates.
 - Use one washer (round Ø 30 x 8 mm SS – 348032) per fixing, under the screw head.
 - *Top end of U-frame:* There are three holes provided at approximately 365 mm to 450 mm from one end of the U-frame. This is the top end of the U-frame, is to be installed toward the ridge of the roof and is the end which will support the solar storage tank.
 - The first hole of these three, closest to the top end of the U-frame (365 mm from the end), must be used to secure the U-frame to the base plate.
 - *Bottom end of U-frame:* There are four slotted holes provided at the other end of the U-frame. This is the bottom end of the U-frame, is to be installed toward the roof gutter and is the end which will support the solar collector(s).
 - Select the slotted hole that provides the correct batten to batten centre distance from the hole used to secure the top base plate to the top end of the U-frame.
- Square up the frame by making sure the diagonals are equidistant and ensure the centre to centre distance between the base plates is equal to the centre to centre distance between the two roof battens.
 - Tighten up the screws in the nutserts.

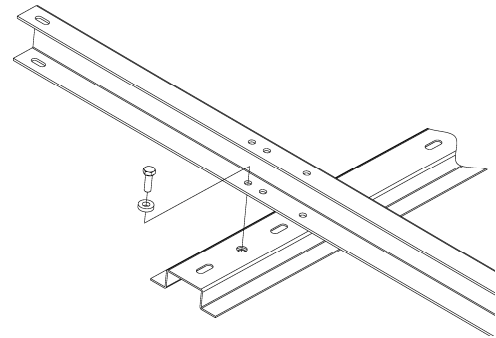

top end of U-frame – assembly guidelines

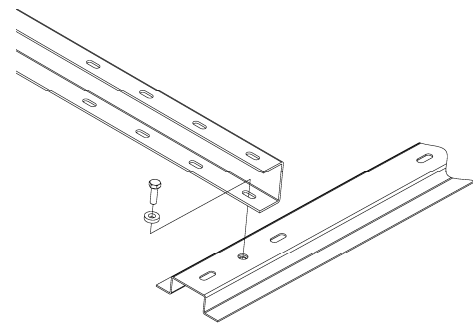

bottom end of U-frame– assembly guidelines

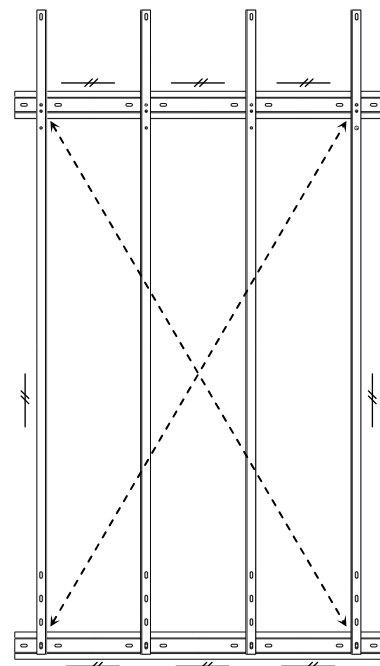

square up frame and check distances

- Position the assembled frame on the roof over the area where it is to be installed, ensuring the base plates are located over the two roof battens.
 - The frame should be located such that the Tek screws or M8 bolts are as close as possible to the rafters or trusses. These Tek screws or bolts are to be supplied by the installer.

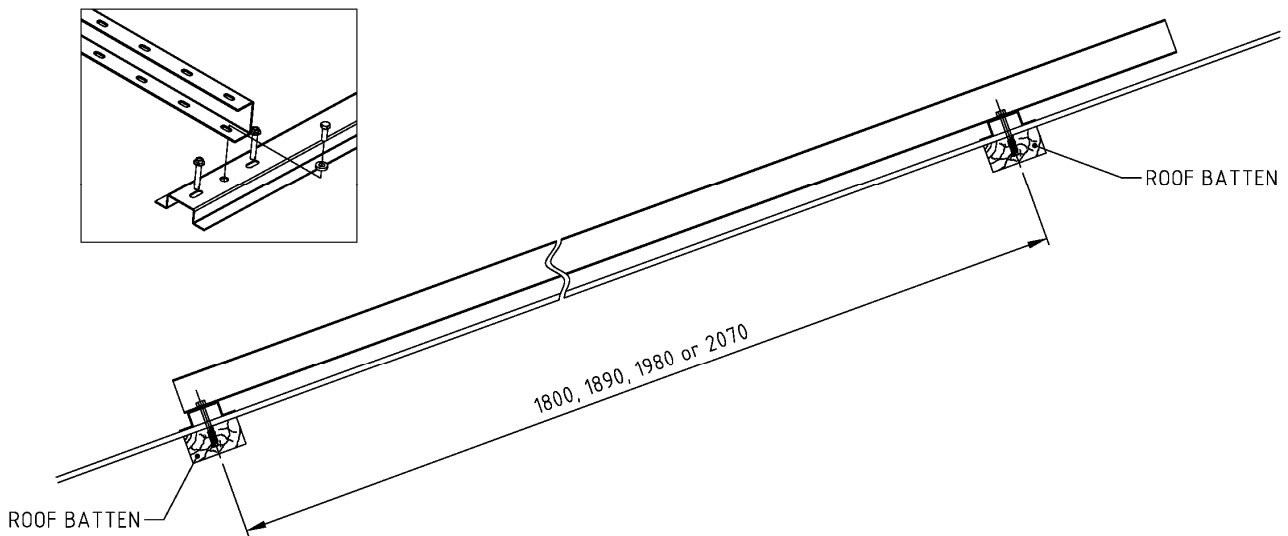

Bolts or Tek screws to penetrate either side of U-frame

- Mark the locations where the Tek screws or M8 bolts are to penetrate the roof material.
 - No. 14 Type 17 HWF Tek Screws are required to fix the base plate to timber battens.
 - M8 bolts are required to fix the base plate to steel battens.
 - The Tek screws or M8 bolts penetrate both the top and bottom base plate through the slotted holes, one on either side of each of the U-frames.
 - There are four fixing points on each base plate for a one collector frame and eight fixing points on each base plate for a two collector frame when using Tek screws or bolts.
- *Timber battens:* Drill through the roof cladding. Fasten the base plates to the timber roof battens using No. 14 Type 17 HWF Tek screws.
 - The Tek screws must penetrate at least 45 mm into the roof battens.

This is the minimum fixing requirement. Refer to Diagram 14 on page 28 for a connection detail.
- *Steel battens:* Drill through the roof cladding and the steel battens. Fasten the base plates to the steel roof battens using M8 bolts and nuts with 20 mm diameter x 3 mm thick washers under both the bolt head and nut.

This is the minimum fixing requirement. Refer to Diagram 15 on page 28 for a connection detail.
- Refer to “Installation of Collector / Tank Rails” on page 29 for the procedure to install the collector rail, tank / collector rail and tank clamps to the U-frames (342558) of the frame.

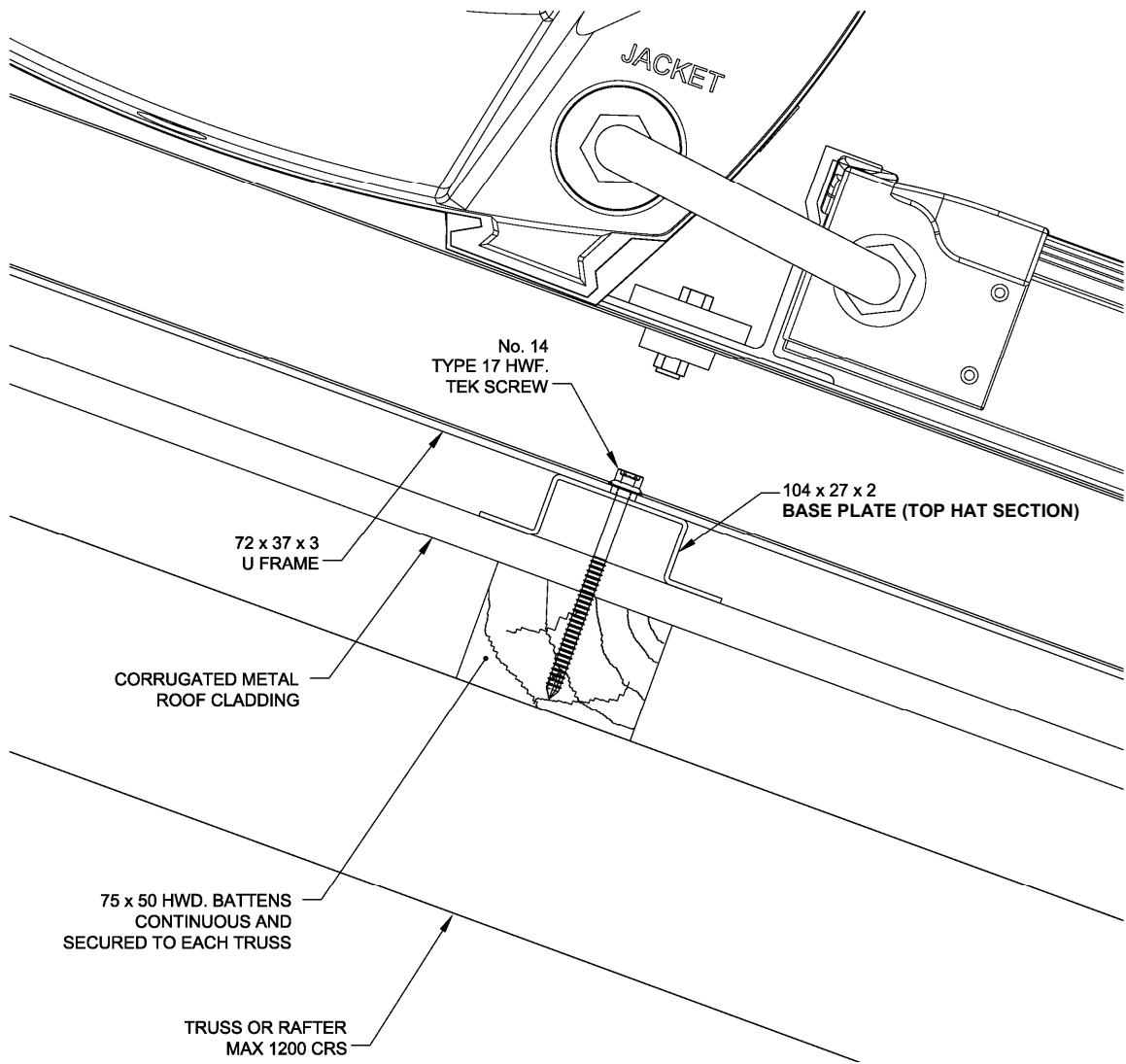

Diagram 14
On Roof Mounting Tek Screw into Timber Batten

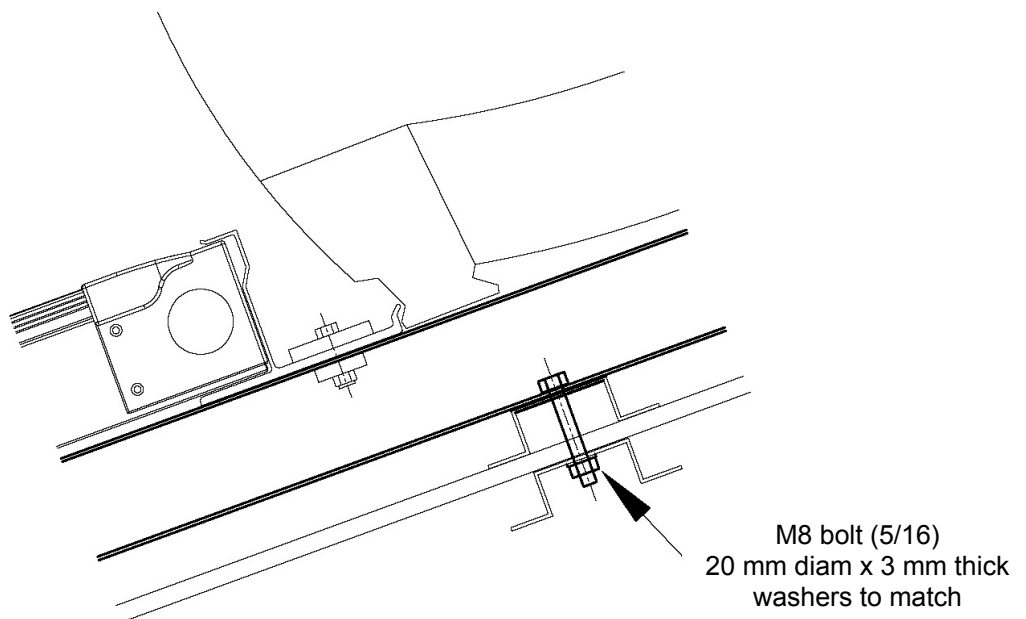
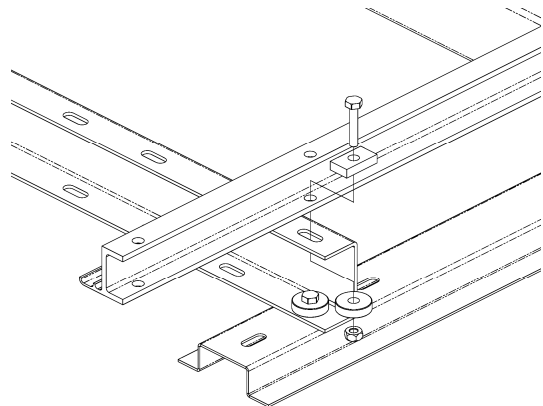

Diagram 15 – On Roof Mounting
Bolt into Steel Batten

INSTALLATION OF COLLECTOR / TANK RAILS

To install the collector rail and tank / collector rail to the U-frames (342558) of the frame:

- Fit the collector rail to each of the U-frames, securing with screws, washers and nuts provided.
 - Use the lowest of the four slotted holes located at the bottom end of the U-frame.
 - Use two washers per fixing;
 - Use one rectangular washer (35 mm x 19 mm x 8 mm SS – 348036) under the screw head.
 - Use one round washer (Ø 30 x 8 mm SS – 348032) under the nut.
 - Tighten up the nuts and screws.
- Fit the tank / collector rail to each of the U-frames, securing with screws, washers and nuts provided.
 - Use the lowest of the three holes in the U-frame, located adjacent to the top base plate.
 - Use two washers per fixing;
 - Use one square washer (50 mm x 50 mm x 8 mm SS – 348034) under the screw head.
 - Use one round washer (Ø 30 x 8 mm SS – 348032) under the nut.
- *Solar storage tank with flat base:*
 - Fit the two Long Tank Straps (343060) to the tank / collector rail and two U-frames.



fit collector rail

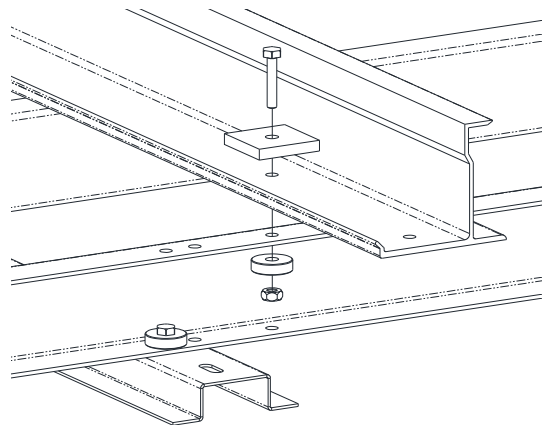

fit tank / collector rail

Position the Tank Straps over the:

- Two U-frames for a 180 tank one collector system.
 - Two inside U-frames for a 180 tank two collector system.
 - Two outside U-frames for a 300 or 305 tank two collector system.
 - Refer to Diagram 12 or 13 on pages 21 and 22 for a three or four collector system installation.
 - The foot, which is orientated inwards, of the Long Tank Strap is to be positioned under the screw head and above the washer (square 50 mm x 50 mm x 8 mm SS – 348034).
- Note:** The Long Tank Strap (343060) is supplied in the Tank Frame Mounting Kit (PN 12103998 or PN 12103999 or PN 12104000).
- Tighten up the nuts and screws.

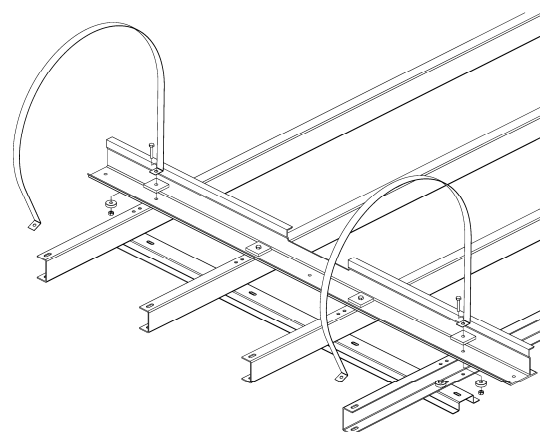

Fit Long Tank Strap to tank / collector rail
(tank with flat base only)
(diagram shows position for 300 or 305 tank
two collector system)

- *Solar storage tank with Z-section feet:*

- Loosely fit the two Rheem tank clamps (343038) to the two outside U-frames, using screws, washers and nuts provided.
 - Use the middle of the three holes provided approximately 385 mm from the top end of the U-frame. This is the hole immediately adjacent to the top tank / rail collector.
 - Use one washer (round 5/16" SS – 330354) under the screw head.
 - Loosely tighten the nuts and screws.

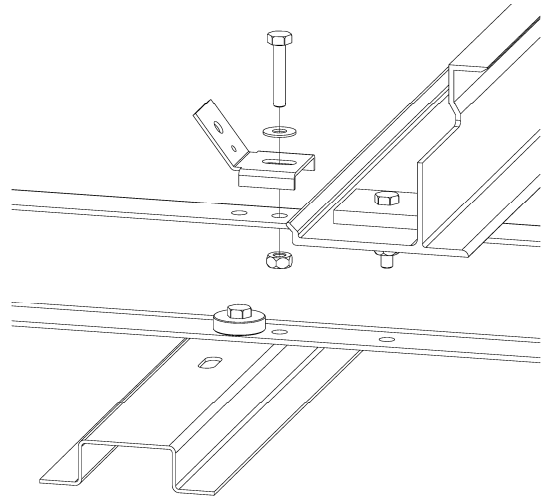

fit tank clamps (for Z-section feet)

- *Solar storage tank with two flat feet:*

- Loosely secure the tank clamps (344121) to the U-frames, using screws, washers and nuts provided.

Position the tank clamps over the:

- Two U-frames for a 150, 180 or 220 tank one collector system.
- Two inside U-frames for a 180 tank two collector system.
- Two outside U-frames for a 220 or 300 tank two collector system.
- Refer to Diagram 4 on page 13 for a 300 tank three collector system.
- Refer to Diagram 5 on page 14 for a 440 tank three collector system.
- Refer to Diagram 6 on page 15 for a 440 tank four collector system.
- **Note:** It is necessary to part the top and bottom halves of the tank clamps along the part line to obtain the two pieces.
 - Place the narrower top half over the wider bottom half of the tank clamp, ensuring the serrated profiles fit together.
 - Use the slotted hole, approximately 20 mm from the top end of the U-frame.
 - Use two washers per fixing;
 - ❖ Use one washer (round 5/16" SS – 330354) under the screw head.
 - ❖ Use one washer (round Ø 30 x 8 mm SS – 348032) under the nut.

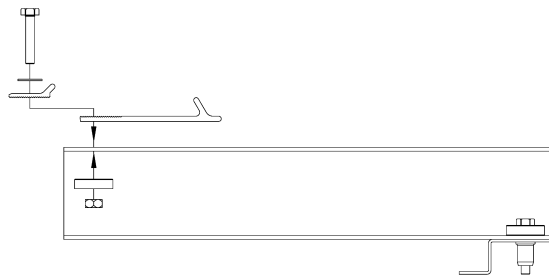

fit tank clamps (for tank with two flat feet)

- Refer to "Installation of Tank and Solar Collectors" on page 31 to complete the installation.

INSTALLATION OF TANK AND SOLAR COLLECTORS

To install the solar storage tank and the solar collectors onto the frame:

- Position the top of the first solar collector into the tank / collector rail and the bottom of the solar collector onto the bottom collector rail.
- Insert the two collector unions (two collector system) into the sockets of the first solar collector and loosely screw each gland nut into its socket.
- Position the top of the second solar collector (two collector system) into the tank / collector rail and the bottom of the solar collector onto the bottom collector rail.
- Slide the second solar collector over the two collector unions and loosely screw each gland nut into its socket.
- Repeat these three steps for a three or four collector system.
- Centralise the solar collector(s) on the frame and tighten the gland nuts (two collector system).

- Loosely fit the collector clamps, two per solar collector, to the bottom collector rail, using a screw, washer and nut provided for each clamp.
 - Use one washer (rectangular 35 mm x 19 mm x 8 mm SS – 348036) per fixing, under the nut.

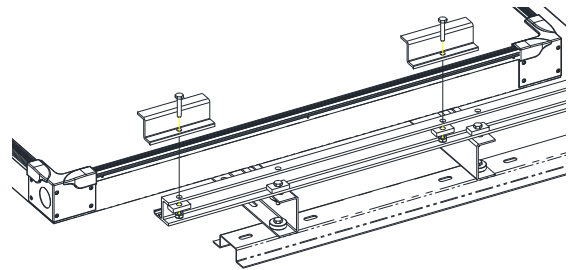

loosely fit collector clamps

- *Solar storage tank with Z-section feet:*
 - Place the solar storage tank on the frame and centralise.
 - Ensure the lower foot of the solar storage tank is placed under the lip of each Rheem tank clamp.

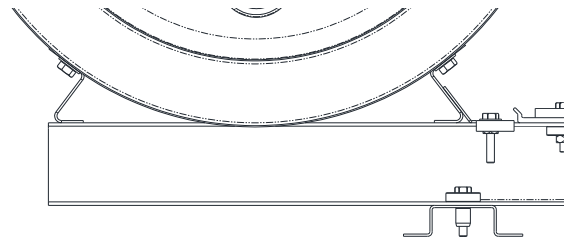

position storage tank (with Z-section feet)

- *Solar storage tank with two flat feet:*
 - Place the solar storage tank on the frame and centralise.
 - Ensure the lower foot of the solar storage tank is placed against the lip of the tank / collector rail.
 - Ensure the higher foot of the solar storage tank is placed between the two lips of each tank clamp. The lip of the bottom half of each tank clamp must be hard up against the tank foot.

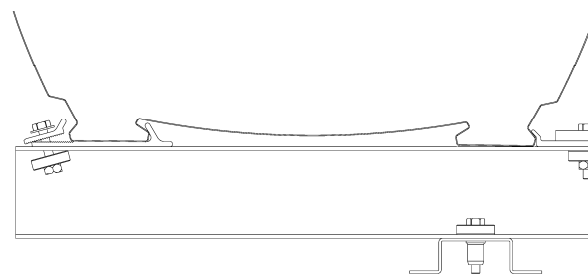

position storage tank (with flat base)

- Loosely fit the tank clamps with a screw, washer and nut provided for each clamp

- *Solar storage tank with flat base*

- **Note:** Prior to placing the solar storage tank on the frame, it is necessary to attach the front and rear reinforcement plates to the front and rear faces of the flat base of the tank. Refer to the installation instructions supplied with the 'Tank Frame Mounting Kit' for the procedure of connecting the reinforcement plates.
- Place the solar storage tank on the frame, wrapping the Long Tank Straps over the tank, and centralise.
- Ensure the front reinforcement plate is placed against the lip of the tank / collector rail.

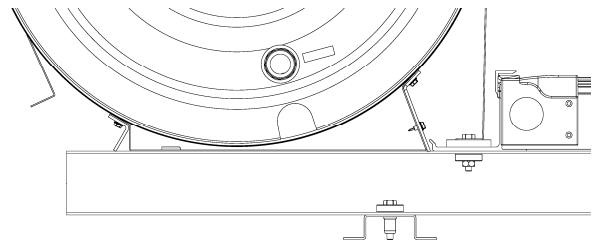

**position storage tank
(with flat base and reinforcement plates)**

- Conduct a final alignment of the solar storage tank and solar collectors.
 - It is necessary to achieve correct alignment in order for the pipe work to fit up neatly.
- Refer to the Installation instructions and Owner's Guide supplied with the water heater for details to complete for the connections to the solar storage tank and solar collector of the solar cold and solar hot pipe work.
- After the solar hot and solar cold pipes are in position and connected to the solar storage tank and solar collectors, tighten up the nut and screw at each collector clamp to secure the solar collector(s).

- *Solar storage tank with Z-section feet:*

- Secure the Z-section foot at the top end of the solar storage tank to the two outside U-frames, using:
 - 1 ½" screws (348033) for a 160 tank, or
 - socket head cap screws (348042) for a 300 tank, and
 - two washers per fixing;
 - ❖ Use one washer (round 5/16" SS – 330354) under the screw head.
 - ❖ Use one washer (round Ø 30 x 8 mm SS – 348032) under the nut.
 - and secure with the nuts provided.
- Align each tank clamp against the Z-section foot at the front of the solar storage tank and tighten the nuts and screws.
- Secure each tank clamp to the Z-section foot at the front of the solar storage tank, using a No. 14 x 20 Tek screw (080071) provided.

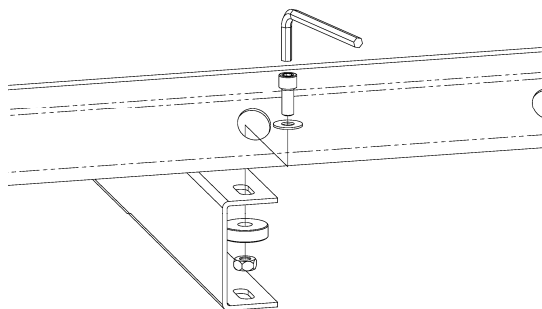

**secure Z-section feet at top side of tank
with socket head cap screw**

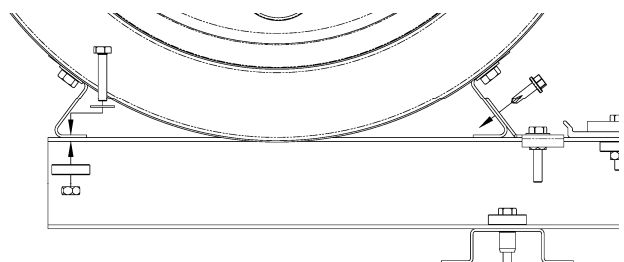

**secure Z-section feet at bottom side of tank
with Tek screw**

- *Solar storage tank with two flat feet:*
 - Position the top plate of the mounting clamp
 - Tighten up the nut and screw at each tank clamp to secure the solar storage tank.

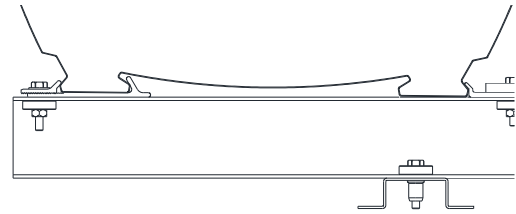

secure storage tank (with flat base)

- *Solar storage tank with flat base:*
 - Position the two tank clamps (343207), one at each U-frame housing a Long Tank Strap, with the shorter angled face of each clamp against the rear reinforcement plate. The hole in the longer angled face should be over the slotted hole at the top end of the U-frame.
 - Fix the tank clamp to the reinforcement plate with the Tek Screw 10G x 16 (080167).
 - **Note:** The tank clamps and 10G x 16 Tek screws are supplied in the Tank Frame Mounting Kit.

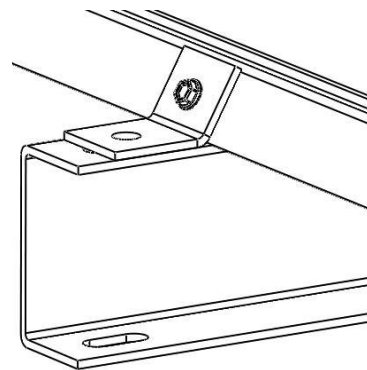
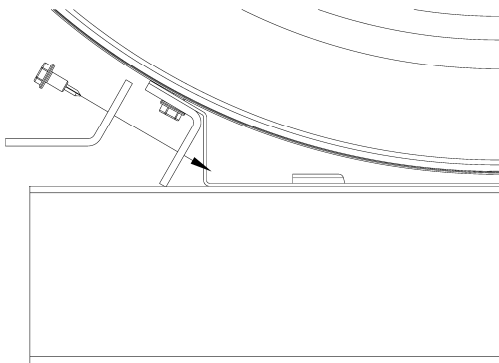

fix tank clamp to reinforcement plate

- Fix a Rear Bracket (short) Tank Strap (343203) to each tank clamp and U-frame using the screws, washers and nuts provided.
 - Ensure the foot of the Rear Bracket (short) Tank Strap is pointing inward toward the tank.
 - Use one washer (round Ø 30 x 8 mm SS – 348032) under the nut.
 - **Note:** The Rear Bracket (short) Tank Straps are supplied in the Tank Frame Mounting Kit.
- Fix the foot of the Long Tank Strap to the upper foot of the Rear Bracket (short) Tank Strap using the screws (348033) and nuts (330806) provided in the Tank Frame Mounting Kit.
 - Tighten the nuts and screws.

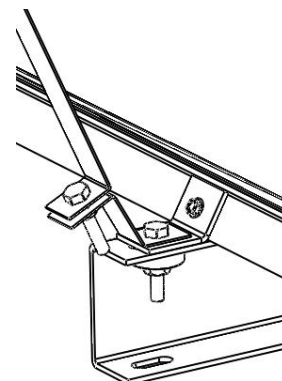
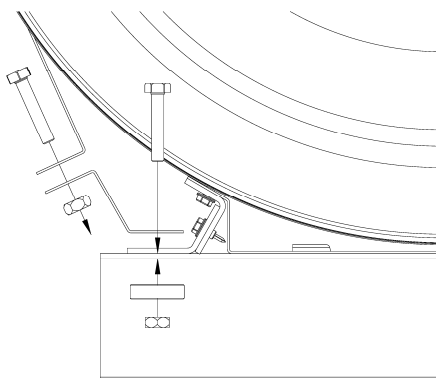

Fix rear bracket tank strap and secure to the long tank strap

SYSTEM CERTIFICATIONS

The structural engineering analysis and design of this With Pitch frame has been conducted and certified by the engineering firm Cardno (NSW) Pty Ltd.

The design is in accordance with normal engineering practice and principals and the relevant sections of the following Australian Standards:

- AS / NZS 1170.0:2002 Structural design actions – Part 0: General principles
- AS / NZS 1170.1:2002 Structural design actions – Part 1: Permanent, imposed and other actions
- AS / NZS 1170.2:2002 Structural design actions – Part 2: Wind actions
- AS / NZS 4600:2005 Cold-formed steel structures
- AS 4100-1998 Steel structures
- AS / NZS 1664.1:1997 Aluminium structures Part 1: Limit design state
- AS 1720.1-1997 Timber structures Part 1: Design methods

To achieve the structural design capacity, it is essential this With Pitch frame be constructed in strict accordance with the fixing details as outlined in these installation instructions.

The design of this frame does not consider the effects of any snow or earthquake loading.

Copies of each certification letter produced by Cardno (NSW) Pty Ltd are reproduced in the following pages.

The certification letter shall not be construed as relieving any other party of their legal responsibilities or contractual obligations.

Our Ref: 605744-LO-40-020

Contact: Ryan Feller

14 September 2010

Rheem Australia Pty Ltd
112 Pilbara St
WELSPPOOL WA 6106

Attention: Mr. Gary Gendall

Cardno (NSW) Pty Ltd
ABN 95 001 145 035

Level 3
Cardno Building
910 Pacific Highway
Gordon NSW 2072
Australia

Phone: 61 2 9496 7700
Fax: 61 2 9499 3902

www.cardno.com.au

Dear Gary,

RE: Solar Hot Water System Steel Framing System No. 020

The structural engineering analysis and design of the following solar hot water system support frame has been conducted by this firm:

Brand Name: Solahart / Rheem / Sunheat / Edwards / Aquamax

Product Description: 1 collector only with pitch anti-cyclone frame

Manufacturer's Name: Rheem Australia PTY LTD

Drawing No. 020 Rev. 1 dated 27/08/2010

We certify that this design is in accordance with normal engineering practice and principals and the relevant sections of the following Australian Standards:

- AS/NZS 1170.0:2002 Structural design actions – Part 0: General principles
- AS/NZS 1170.1:2002 Structural design actions – Part 1: Permanent, imposed and other actions
- AS/NZS 1170.2:2002 Structural design actions – Part 2: Wind Actions
- AS/NZS 4600:2005 Cold-formed steel structures
- AS 4100-1998 Steel structures
- AS/NZS 1664.1:1997 Aluminium structures Part 1: Limit state design
- AS 1720.1-1997 Timber structures Part 1: Design methods

The design of this support frame does not consider the effects of any snow or earthquake loading. In conjunction with AS/NZS 1170.2:2002 the frame has been designed to withstand wind loads up to and including region D, terrain category 2, installed at a maximum height of 10m (design wind speed 88m/s). This loading exceeds the requirements of Wind class N6/C4 when assessed in accordance with AS4055-2006 Wind loads for housing.

To achieve the structural design capacity, it is essential that the steel frame structure be constructed in a strict accordance with the fixing details provided by the manufacturer's specification.

It is noted that this certification relates to the design of the framing systems only, and that no structural assessment of water storage tanks or collector panels has been conducted. It is further noted that verification of the roofs capacity to withstand any additional loads imposed by the solar hot water system is outside of the scope of this certificate. No assessment has been made of any specific site as part of the design.

This certificate shall not be construed as relieving any other party of their legal responsibilities or contractual obligations.

Yours faithfully,



MARK HICKEY

Discipline Leader - Structures
for **Cardno (NSW)**

NT Certifying Engineer Reference # 32942ES
RPEQ # 1649

Our Ref: 605744-LO-40-029

Contact: Ryan Feller

14 September 2010

Rheem Australia Pty Ltd
112 Pilbara St
WELSPool WA 6106

Attention: Mr. Gary Gendall

Dear Gary,

RE: Solar Hot Water System Steel Framing System No. 029

The structural engineering analysis and design of the following solar hot water system support frame has been conducted by this firm:

Brand Name: Solahart / Rheem / Sunheat / Edwards / Aquamax

Product Description: 2 collector only with pitch anti-cyclone frame

Manufacturer's Name: Rheem Australia PTY LTD

Drawing No. 029 Rev. 1 dated 27/08/2010

Cardno (NSW) Pty Ltd
ABN 95 001 145 035

Level 3
Cardno Building
910 Pacific Highway
Gordon NSW 2072
Australia

Phone: 61 2 9496 7700
Fax: 61 2 9499 3902

www.cardno.com.au

We certify that this design is in accordance with normal engineering practice and principals and the relevant sections of the following Australian Standards:

- AS/NZS 1170.0:2002 Structural design actions – Part 0: General principles
- AS/NZS 1170.1:2002 Structural design actions – Part 1: Permanent, imposed and other actions
- AS/NZS 1170.2:2002 Structural design actions – Part 2: Wind Actions
- AS/NZS 4600:2005 Cold-formed steel structures
- AS 4100-1998 Steel structures
- AS/NZS 1664.1:1997 Aluminium structures Part 1: Limit state design
- AS 1720.1-1997 Timber structures Part 1: Design methods

The design of this support frame does not consider the effects of any snow or earthquake loading. In conjunction with AS/NZS 1170.2:2002 the frame has been designed to withstand wind loads up to and including region D, terrain category 2, installed at a maximum height of 10m (design wind speed 88m/s). This loading exceeds the requirements of Wind class N6/C4 when assessed in accordance with AS4055-2006 Wind loads for housing.

To achieve the structural design capacity, it is essential that the steel frame structure be constructed in a strict accordance with the fixing details provided by the manufacturer's specification.

It is noted that this certification relates to the design of the framing systems only, and that no structural assessment of water storage tanks or collector panels has been conducted. It is further noted that verification of the roofs capacity to withstand any additional loads imposed by the solar hot water system is outside of the scope of this certificate. No assessment has been made of any specific site as part of the design.

This certificate shall not be construed as relieving any other party of their legal responsibilities or contractual obligations.

Yours faithfully,



MARK HICKEY
Discipline Leader - Structures
for **Cardno (NSW)**
NT Certifying Engineer Reference # 32942ES
RPEQ # 1649

Our Ref: 605744-LO-43-026

Contact: Ryan Feller

8 October 2010

Rheem Australia Pty Ltd
112 Pilbara St
WELSPPOOL WA 6106

Attention: Mr. Gary Gendall

Cardno (NSW) Pty Ltd
ABN 95 001 145 035

Level 3
Cardno Building
910 Pacific Highway
Gordon NSW 2072
Australia

Phone: 61 2 9496 7700
Fax: 61 2 9499 3902

www.cardno.com.au

Dear Gary,

RE: Solar Hot Water Support Frame No. 026

The structural engineering analysis and design of the following solar hot water system support frame has been conducted by this firm:

Brand Name: Edwards

Product Description: 1 collector with pitch anti-cyclone frame 180 litre tank

Manufacturer's Name: Rheem Australia PTY LTD

Drawing No. 025 Rev. 2 dated 15/09/2010

We certify that this design is in accordance with normal engineering practice and principals and the relevant sections of the following Australian Standards:

- AS/NZS 1170.0:2002 Structural design actions – Part 0: General principles
- AS/NZS 1170.1:2002 Structural design actions – Part 1: Permanent, imposed and other actions
- AS/NZS 1170.2:2002 Structural design actions – Part 2: Wind Actions
- AS/NZS 4600:2005 Cold-formed steel structures
- AS 4100-1998 Steel structures
- AS/NZS 1664.1:1997 Aluminium structures Part 1: Limit state design
- AS 1720.1-1997 Timber structures Part 1: Design methods

The design of this support frame does not consider the effects of any snow or earthquake loading. In conjunction with AS/NZS 1170.2:2002 the frame has been designed to withstand wind loads up to and including region D, terrain category 2, installed at a maximum height of 10m (design wind speed 88m/s). This loading exceeds the requirements of Wind class N6/C4 when assessed in accordance with AS4055-2006 Wind loads for housing.

To achieve the structural design capacity, it is essential that the steel frame structure be constructed in a strict accordance with the fixing details provided by the manufacturer's specification.

It is noted that this certification relates to the design of the framing systems only, and that no structural assessment of water storage tanks or collector panels has been conducted. It is further noted that verification of the roofs capacity to withstand any additional loads imposed by the solar hot water system is outside of the scope of this certificate.

This certificate shall not be construed as relieving any other party of their legal responsibilities or contractual obligations.

Yours faithfully,



MARK HICKEY
Discipline Leader - Structures
for Cardno (NSW)
NT Certifying Engineer Reference # 32942ES
RPEQ # 01649

Our Ref: 605744-LO-43-036

Contact: Ryan Feller

8 October 2010

Rheem Australia Pty Ltd
112 Pilbara St
WELSPool WA 6106

Attention: Mr. Gary Gendall

Cardno (NSW) Pty Ltd
ABN 95 001 145 035

Level 3
Cardno Building
910 Pacific Highway
Gordon NSW 2072
Australia

Phone: 61 2 9496 7700
Fax: 61 2 9499 3902

www.cardno.com.au

Dear Gary,

RE: Solar Hot Water Support Frame No. 036

The structural engineering analysis and design of the following solar hot water system support frame has been conducted by this firm:

Brand Name: Edwards

Product Description: 2 collector with pitch anti-cyclone frame 180 litre tank

Manufacturer's Name: Rheem Australia PTY LTD

Drawing No. 036 Rev. 1 dated 15/09/2010

We certify that this design is in accordance with normal engineering practice and principals and the relevant sections of the following Australian Standards:

- AS/NZS 1170.0:2002 Structural design actions – Part 0: General principles
- AS/NZS 1170.1:2002 Structural design actions – Part 1: Permanent, imposed and other actions
- AS/NZS 1170.2:2002 Structural design actions – Part 2: Wind Actions
- AS/NZS 4600:2005 Cold-formed steel structures
- AS 4100-1998 Steel structures
- AS/NZS 1664.1:1997 Aluminium structures Part 1: Limit state design
- AS 1720.1-1997 Timber structures Part 1: Design methods

The design of this support frame does not consider the effects of any snow or earthquake loading. In conjunction with AS/NZS 1170.2:2002 the frame has been designed to withstand wind loads up to and including region D, terrain category 2, installed at a maximum height of 10m (design wind speed 88m/s). This loading exceeds the requirements of Wind class N6/C4 when assessed in accordance with AS4055-2006 Wind loads for housing.

To achieve the structural design capacity, it is essential that the steel frame structure be constructed in a strict accordance with the fixing details provided by the manufacturer's specification.

It is noted that this certification relates to the design of the framing systems only, and that no structural assessment of water storage tanks or collector panels has been conducted. It is further noted that verification of the roofs capacity to withstand any additional loads imposed by the solar hot water system is outside of the scope of this certificate.

This certificate shall not be construed as relieving any other party of their legal responsibilities or contractual obligations.

Yours faithfully,



MARK HICKEY

*Discipline Leader - Structures
for Cardno (NSW)*

NT Certifying Engineer Reference # 32942ES
RPEQ # 01649

Our Ref: 605744-LO-43-037

Contact: Ryan Feller

8 October 2010

Rheem Australia Pty Ltd
112 Pilbara St
WELSPOOL WA 6106

Attention: Mr. Gary Gendall

Cardno (NSW) Pty Ltd
ABN 95 001 145 035

Level 3
Cardno Building
910 Pacific Highway
Gordon NSW 2072
Australia

Phone: 61 2 9496 7700
Fax: 61 2 9499 3902

www.cardno.com.au

Dear Gary,

RE: Solar Hot Water Support Frame No. 037

The structural engineering analysis and design of the following solar hot water system support frame has been conducted by this firm:

Brand Name: Edwards

Product Description: 2 collector with pitch anti-cyclone frame 305 litre tank

Manufacturer's Name: Rheem Australia PTY LTD

Drawing No. 035 Rev. 2 dated 15/09/2010

We certify that this design is in accordance with normal engineering practice and principals and the relevant sections of the following Australian Standards:

- AS/NZS 1170.0:2002 Structural design actions – Part 0: General principles
- AS/NZS 1170.1:2002 Structural design actions – Part 1: Permanent, imposed and other actions
- AS/NZS 1170.2:2002 Structural design actions – Part 2: Wind Actions
- AS/NZS 4600:2005 Cold-formed steel structures
- AS 4100-1998 Steel structures
- AS/NZS 1664.1:1997 Aluminium structures Part 1: Limit state design
- AS 1720.1-1997 Timber structures Part 1: Design methods

The design of this support frame does not consider the effects of any snow or earthquake loading. In conjunction with AS/NZS 1170.2:2002 the frame has been designed to withstand wind loads up to and including region D, terrain category 2, installed at a maximum height of 10m (design wind speed 88m/s). This loading exceeds the requirements of Wind class N6/C4 when assessed in accordance with AS4055-2006 Wind loads for housing.

To achieve the structural design capacity, it is essential that the steel frame structure be constructed in a strict accordance with the fixing details provided by the manufacturer's specification.

It is noted that this certification relates to the design of the framing systems only, and that no structural assessment of water storage tanks or collector panels has been conducted. It is further noted that verification of the roofs capacity to withstand any additional loads imposed by the solar hot water system is outside of the scope of this certificate.

This certificate shall not be construed as relieving any other party of their legal responsibilities or contractual obligations.

Yours faithfully,



MARK HICKEY
Discipline Leader - Structures
for **Cardno (NSW)**
NT Certifying Engineer Reference # 32942ES
RPEQ # 01649

Our Ref: 605744-LO-45-043

Contact: Ryan Feller

18 October 2010

Rheem Australia Pty Ltd
112 Pilbara St
WELSPOOL WA 6106

Attention: Mr. Gary Gendall

Cardno (NSW) Pty Ltd
ABN 95 001 145 035

Level 3
Cardno Building
910 Pacific Highway
Gordon NSW 2072
Australia

Phone: 61 2 9496 7700
Fax: 61 2 9499 3902

www.cardno.com.au

Dear Gary,

RE: Solar Hot Water Support Frame No. 043

The structural engineering analysis and design of the following solar hot water system support frame has been conducted by this firm:

Brand Name: Edwards

Product Description: 3 collector with pitch anti-cyclone frame 305 litre tank

Manufacturer's Name: Rheem Australia PTY LTD

Drawing No. 043 Rev. 1 dated 11/10/2010

We certify that this design is in accordance with normal engineering practice and principals and the relevant sections of the following Australian Standards:

- AS/NZS 1170.0:2002 Structural design actions – Part 0: General principles
- AS/NZS 1170.1:2002 Structural design actions – Part 1: Permanent, imposed and other actions
- AS/NZS 1170.2:2002 Structural design actions – Part 2: Wind Actions
- AS/NZS 4600:2005 Cold-formed steel structures
- AS 4100-1998 Steel structures
- AS/NZS 1664.1:1997 Aluminium structures Part 1: Limit state design
- AS 1720.1-1997 Timber structures Part 1: Design methods

The design of this support frame does not consider the effects of any snow or earthquake loading. In conjunction with AS/NZS 1170.2:2002 the frame has been designed to withstand wind loads up to and including region D, terrain category 2, installed at a maximum height of 10m (design wind speed 88m/s). This loading exceeds the requirements of Wind class N6/C4 when assessed in accordance with AS4055-2006 Wind loads for housing.

To achieve the structural design capacity, it is essential that the steel frame structure be constructed in a strict accordance with the fixing details provided by the manufacturer's specification.

It is noted that this certification relates to the design of the framing systems only, and that no structural assessment of water storage tanks or collector panels has been conducted. It is further noted that verification of the roofs capacity to withstand any additional loads imposed by the solar hot water system is outside of the scope of this certificate.

This certificate shall not be construed as relieving any other party of their legal responsibilities or contractual obligations.

Yours faithfully,



MARK HICKEY
Discipline Leader - Structures
for **Cardno (NSW)**
NT Certifying Engineer Reference # 32942ES
RPEQ # 01649

Our Ref: 605744-LO-45-044

Contact: Ryan Feller

18 October 2010

Rheem Australia Pty Ltd
112 Pilbara St
WELSPOOL WA 6106

Attention: Mr. Gary Gendall

Cardno (NSW) Pty Ltd
ABN 95 001 145 035

Level 3
Cardno Building
910 Pacific Highway
Gordon NSW 2072
Australia

Phone: 61 2 9496 7700
Fax: 61 2 9499 3902

www.cardno.com.au

Dear Gary,

RE: Solar Hot Water Support Frame No. 044

The structural engineering analysis and design of the following solar hot water system support frame has been conducted by this firm:

Brand Name: Edwards

Product Description: 3 collector with pitch anti-cyclone frame 440 litre tank

Manufacturer's Name: Rheem Australia PTY LTD

Drawing No. 044 Rev. 1 dated 11/10/2010

We certify that this design is in accordance with normal engineering practice and principals and the relevant sections of the following Australian Standards:

- AS/NZS 1170.0:2002 Structural design actions – Part 0: General principles
- AS/NZS 1170.1:2002 Structural design actions – Part 1: Permanent, imposed and other actions
- AS/NZS 1170.2:2002 Structural design actions – Part 2: Wind Actions
- AS/NZS 4600:2005 Cold-formed steel structures
- AS 4100-1998 Steel structures
- AS/NZS 1664.1:1997 Aluminium structures Part 1: Limit state design
- AS 1720.1-1997 Timber structures Part 1: Design methods

The design of this support frame does not consider the effects of any snow or earthquake loading. In conjunction with AS/NZS 1170.2:2002 the frame has been designed to withstand wind loads up to and including region D, terrain category 2, installed at a maximum height of 10m (design wind speed 88m/s). This loading exceeds the requirements of Wind class N6/C4 when assessed in accordance with AS4055-2006 Wind loads for housing.

To achieve the structural design capacity, it is essential that the steel frame structure be constructed in a strict accordance with the fixing details provided by the manufacturer's specification.

It is noted that this certification relates to the design of the framing systems only, and that no structural assessment of water storage tanks or collector panels has been conducted. It is further noted that verification of the roofs capacity to withstand any additional loads imposed by the solar hot water system is outside of the scope of this certificate.

This certificate shall not be construed as relieving any other party of their legal responsibilities or contractual obligations.

Yours faithfully,



MARK HICKEY
Discipline Leader - Structures
for **Cardno (NSW)**
NT Certifying Engineer Reference # 32942ES
RPEQ # 01649

Our Ref: 605744-LO-45-047

Contact: Ryan Feller

18 October 2010

Rheem Australia Pty Ltd
112 Pilbara St
WELSPPOOL WA 6106

Attention: Mr. Gary Gendall

Cardno (NSW) Pty Ltd
ABN 95 001 145 035

Level 3
Cardno Building
910 Pacific Highway
Gordon NSW 2072
Australia

Phone: 61 2 9496 7700
Fax: 61 2 9499 3902

www.cardno.com.au

Dear Gary,

RE: Solar Hot Water Support Frame No. 047

The structural engineering analysis and design of the following solar hot water system support frame has been conducted by this firm:

Brand Name: Edwards

Product Description: 4 collector with pitch anti-cyclone frame 440 litre tank

Manufacturer's Name: Rheem Australia PTY LTD

Drawing No. 047 Rev. 1 dated 11/10/2010

We certify that this design is in accordance with normal engineering practice and principals and the relevant sections of the following Australian Standards:

- AS/NZS 1170.0:2002 Structural design actions – Part 0: General principles
- AS/NZS 1170.1:2002 Structural design actions – Part 1: Permanent, imposed and other actions
- AS/NZS 1170.2:2002 Structural design actions – Part 2: Wind Actions
- AS/NZS 4600:2005 Cold-formed steel structures
- AS 4100-1998 Steel structures
- AS/NZS 1664.1:1997 Aluminium structures Part 1: Limit state design
- AS 1720.1-1997 Timber structures Part 1: Design methods

The design of this support frame does not consider the effects of any snow or earthquake loading. In conjunction with AS/NZS 1170.2:2002 the frame has been designed to withstand wind loads up to and including region D, terrain category 2, installed at a maximum height of 10m (design wind speed 88m/s). This loading exceeds the requirements of Wind class N6/C4 when assessed in accordance with AS4055-2006 Wind loads for housing.

To achieve the structural design capacity, it is essential that the steel frame structure be constructed in a strict accordance with the fixing details provided by the manufacturer's specification.

It is noted that this certification relates to the design of the framing systems only, and that no structural assessment of water storage tanks or collector panels has been conducted. It is further noted that verification of the roofs capacity to withstand any additional loads imposed by the solar hot water system is outside of the scope of this certificate.

This certificate shall not be construed as relieving any other party of their legal responsibilities or contractual obligations.

Yours faithfully,



MARK HICKEY
Discipline Leader - Structures
for **Cardno (NSW)**
NT Certifying Engineer Reference # 32942ES
RPEQ # 01649

Our Ref: 605744-LO-43-024

Contact: Ryan Feller

8 October 2010

Rheem Australia Pty Ltd
112 Pilbara St
WELSPool WA 6106

Attention: Mr. Gary Gendall

Cardno (NSW) Pty Ltd
ABN 95 001 145 035

Level 3
Cardno Building
910 Pacific Highway
Gordon NSW 2072
Australia

Phone: 61 2 9496 7700
Fax: 61 2 9499 3902

www.cardno.com.au

Dear Gary,

RE: Solar Hot Water Support Frame No. 024

The structural engineering analysis and design of the following solar hot water system support frame has been conducted by this firm:

Brand Name: Rheem

Product Description: 1 collector with pitch anti-cyclone frame 160 litre tank

Manufacturer's Name: Rheem Australia PTY LTD

Drawing No. 024 Rev. 2 dated 15/09/2010

We certify that this design is in accordance with normal engineering practice and principals and the relevant sections of the following Australian Standards:

- AS/NZS 1170.0:2002 Structural design actions – Part 0: General principles
- AS/NZS 1170.1:2002 Structural design actions – Part 1: Permanent, imposed and other actions
- AS/NZS 1170.2:2002 Structural design actions – Part 2: Wind Actions
- AS/NZS 4600:2005 Cold-formed steel structures
- AS 4100-1998 Steel structures
- AS/NZS 1664.1:1997 Aluminium structures Part 1: Limit state design
- AS 1720.1-1997 Timber structures Part 1: Design methods

The design of this support frame does not consider the effects of any snow or earthquake loading. In conjunction with AS/NZS 1170.2:2002 the frame has been designed to withstand wind loads up to and including region D, terrain category 2, installed at a maximum height of 10m (design wind speed 88m/s). This loading exceeds the requirements of Wind class N6/C4 when assessed in accordance with AS4055-2006 Wind loads for housing.

To achieve the structural design capacity, it is essential that the steel frame structure be constructed in a strict accordance with the fixing details provided by the manufacturer's specification.

It is noted that this certification relates to the design of the framing systems only, and that no structural assessment of water storage tanks or collector panels has been conducted. It is further noted that verification of the roofs capacity to withstand any additional loads imposed by the solar hot water system is outside of the scope of this certificate.

This certificate shall not be construed as relieving any other party of their legal responsibilities or contractual obligations.

Yours faithfully,



MARK HICKEY
Discipline Leader - Structures
for Cardno (NSW)
NT Certifying Engineer Reference # 32942ES
RPEQ # 01649

Our Ref: 605744-LO-43-034

Contact: Ryan Feller

8 October 2010

Rheem Australia Pty Ltd
112 Pilbara St
WELSPOOL WA 6106

Attention: Mr. Gary Gendall

Dear Gary,

RE: Solar Hot Water Support Frame No. 034

The structural engineering analysis and design of the following solar hot water system support frame has been conducted by this firm:

Brand Name: Rheem Hiline

Product Description: 2 collector with pitch anti-cyclone frame 300 litre tank

Manufacturer's Name: Rheem Australia PTY LTD

Drawing No. 034 Rev. 2 dated 15/09/2010

We certify that this design is in accordance with normal engineering practice and principals and the relevant sections of the following Australian Standards:

- AS/NZS 1170.0:2002 Structural design actions – Part 0: General principles
- AS/NZS 1170.1:2002 Structural design actions – Part 1: Permanent, imposed and other actions
- AS/NZS 1170.2:2002 Structural design actions – Part 2: Wind Actions
- AS/NZS 4600:2005 Cold-formed steel structures
- AS 4100-1998 Steel structures
- AS/NZS 1664.1:1997 Aluminium structures Part 1: Limit state design
- AS 1720.1-1997 Timber structures Part 1: Design methods

The design of this support frame does not consider the effects of any snow or earthquake loading. In conjunction with AS/NZS 1170.2:2002 the frame has been designed to withstand wind loads up to and including region D, terrain category 2, installed at a maximum height of 10m (design wind speed 88m/s). This loading exceeds the requirements of Wind class N6/C4 when assessed in accordance with AS4055-2006 Wind loads for housing.

Cardno (NSW) Pty Ltd
ABN 95 001 145 035

Level 3
Cardno Building
910 Pacific Highway
Gordon NSW 2072
Australia

Phone: 61 2 9496 7700
Fax: 61 2 9499 3902

www.cardno.com.au

To achieve the structural design capacity, it is essential that the steel frame structure be constructed in a strict accordance with the fixing details provided by the manufacturer's specification.

It is noted that this certification relates to the design of the framing systems only, and that no structural assessment of water storage tanks or collector panels has been conducted. It is further noted that verification of the roofs capacity to withstand any additional loads imposed by the solar hot water system is outside of the scope of this certificate.

This certificate shall not be construed as relieving any other party of their legal responsibilities or contractual obligations.

Yours faithfully,



MARK HICKEY
Discipline Leader - Structures
for Cardno (NSW)
NT Certifying Engineer Reference # 32942ES
RPEQ # 01649

Our Ref: 605744-LO-43-025

Contact: Ryan Feller

8 October 2010

Rheem Australia Pty Ltd
112 Pilbara St
WELSPPOOL WA 6106

Attention: Mr. Gary Gendall

Cardno (NSW) Pty Ltd
ABN 95 001 145 035

Level 3
Cardno Building
910 Pacific Highway
Gordon NSW 2072
Australia

Phone: 61 2 9496 7700
Fax: 61 2 9499 3902

www.cardno.com.au

Dear Gary,

RE: Solar Hot Water Support Frame No. 025

The structural engineering analysis and design of the following solar hot water system support frame has been conducted by this firm:

Brand Name: Rheem Premier Hiline

Product Description: 1 collector with pitch anti-cyclone frame 180 litre tank

Manufacturer's Name: Rheem Australia PTY LTD

Drawing No. 025 Rev. 2 dated 15/09/2010

We certify that this design is in accordance with normal engineering practice and principals and the relevant sections of the following Australian Standards:

- AS/NZS 1170.0:2002 Structural design actions – Part 0: General principles
- AS/NZS 1170.1:2002 Structural design actions – Part 1: Permanent, imposed and other actions
- AS/NZS 1170.2:2002 Structural design actions – Part 2: Wind Actions
- AS/NZS 4600:2005 Cold-formed steel structures
- AS 4100-1998 Steel structures
- AS/NZS 1664.1:1997 Aluminium structures Part 1: Limit state design
- AS 1720.1-1997 Timber structures Part 1: Design methods

The design of this support frame does not consider the effects of any snow or earthquake loading. In conjunction with AS/NZS 1170.2:2002 the frame has been designed to withstand wind loads up to and including region D, terrain category 2, installed at a maximum height of 10m (design wind speed 88m/s). This loading exceeds the requirements of Wind class N6/C4 when assessed in accordance with AS4055-2006 Wind loads for housing.

To achieve the structural design capacity, it is essential that the steel frame structure be constructed in a strict accordance with the fixing details provided by the manufacturer's specification.

It is noted that this certification relates to the design of the framing systems only, and that no structural assessment of water storage tanks or collector panels has been conducted. It is further noted that verification of the roofs capacity to withstand any additional loads imposed by the solar hot water system is outside of the scope of this certificate.

This certificate shall not be construed as relieving any other party of their legal responsibilities or contractual obligations.

Yours faithfully,



MARK HICKEY
Discipline Leader - Structures
for Cardno (NSW)
NT Certifying Engineer Reference # 32942ES
RPEQ # 01649

Our Ref: 605744-LO-43-035

Contact: Ryan Feller

8 October 2010

Rheem Australia Pty Ltd
112 Pilbara St
WELSPool WA 6106

Attention: Mr. Gary Gendall

Dear Gary,

RE: Solar Hot Water Support Frame No. 035

The structural engineering analysis and design of the following solar hot water system support frame has been conducted by this firm:

Brand Name: Rheem Premier Hiline

Product Description: 2 collector with pitch anti-cyclone frame 305 litre tank

Manufacturer's Name: Rheem Australia PTY LTD

Drawing No. 035 Rev. 2 dated 15/09/2010

We certify that this design is in accordance with normal engineering practice and principals and the relevant sections of the following Australian Standards:

- AS/NZS 1170.0:2002 Structural design actions – Part 0: General principles
- AS/NZS 1170.1:2002 Structural design actions – Part 1: Permanent, imposed and other actions
- AS/NZS 1170.2:2002 Structural design actions – Part 2: Wind Actions
- AS/NZS 4600:2005 Cold-formed steel structures
- AS 4100-1998 Steel structures
- AS/NZS 1664.1:1997 Aluminium structures Part 1: Limit state design
- AS 1720.1-1997 Timber structures Part 1: Design methods

The design of this support frame does not consider the effects of any snow or earthquake loading. In conjunction with AS/NZS 1170.2:2002 the frame has been designed to withstand wind loads up to and including region D, terrain category 2, installed at a maximum height of 10m (design wind speed 88m/s). This loading exceeds the requirements of Wind class N6/C4 when assessed in accordance with AS4055-2006 Wind loads for housing.

Cardno (NSW) Pty Ltd
ABN 95 001 145 035

Level 3
Cardno Building
910 Pacific Highway
Gordon NSW 2072
Australia

Phone: 61 2 9496 7700
Fax: 61 2 9499 3902

www.cardno.com.au

To achieve the structural design capacity, it is essential that the steel frame structure be constructed in a strict accordance with the fixing details provided by the manufacturer's specification.

It is noted that this certification relates to the design of the framing systems only, and that no structural assessment of water storage tanks or collector panels has been conducted. It is further noted that verification of the roofs capacity to withstand any additional loads imposed by the solar hot water system is outside of the scope of this certificate.

This certificate shall not be construed as relieving any other party of their legal responsibilities or contractual obligations.

Yours faithfully,



MARK HICKEY
Discipline Leader - Structures
for **Cardno (NSW)**

NT Certifying Engineer Reference # 32942ES
RPEQ # 01649

Our Ref: 605744-LO-40-021

Contact: Ryan Feller

14 September 2010

Rheem Australia Pty Ltd
112 Pilbara St
WELSPool WA 6106

Attention: Mr. Gary Gendall

Dear Gary,

RE: Solar Hot Water System Steel Framing System No. 021

The structural engineering analysis and design of the following solar hot water system support frame has been conducted by this firm:

Brand Name: Solahart

Product Description: 1 collector with pitch anti-cyclone frame 150 litre tank

Manufacturer's Name: Rheem Australia PTY LTD

Drawing No. 021 Rev. 1 dated 30/08/2010

We certify that this design is in accordance with normal engineering practice and principals and the relevant sections of the following Australian Standards:

- AS/NZS 1170.0:2002 Structural design actions – Part 0: General principles
- AS/NZS 1170.1:2002 Structural design actions – Part 1: Permanent, imposed and other actions
- AS/NZS 1170.2:2002 Structural design actions – Part 2: Wind Actions
- AS/NZS 4600:2005 Cold-formed steel structures
- AS 4100-1998 Steel structures
- AS/NZS 1664.1:1997 Aluminium structures Part 1: Limit state design
- AS 1720.1-1997 Timber structures Part 1: Design methods

The design of this support frame does not consider the effects of any snow or earthquake loading. In conjunction with AS/NZS 1170.2:2002 the frame has been designed to withstand wind loads up to and including region D, terrain category 2, installed at a maximum height of 10m (design wind speed 88m/s). This loading exceeds the requirements of Wind class N6/C4 when assessed in accordance with AS4055-2006 Wind loads for housing.

Cardno (NSW) Pty Ltd
ABN 95 001 145 035

Level 3
Cardno Building
910 Pacific Highway
Gordon NSW 2072
Australia

Phone: 61 2 9496 7700
Fax: 61 2 9499 3902

www.cardno.com.au

To achieve the structural design capacity, it is essential that the steel frame structure be constructed in a strict accordance with the fixing details provided by the manufacturer's specification.

It is noted that this certification relates to the design of the framing systems only, and that no structural assessment of water storage tanks or collector panels has been conducted. It is further noted that verification of the roofs capacity to withstand any additional loads imposed by the solar hot water system is outside of the scope of this certificate. No assessment has been made of any specific site as part of the design.

This certificate shall not be construed as relieving any other party of their legal responsibilities or contractual obligations.

Yours faithfully,



MARK HICKEY

Discipline Leader - Structures

for **Cardno (NSW)**

NT Certifying Engineer Reference # 32942ES

RPEQ # 1649

Our Ref: 605744-LO-40-022

Contact: Ryan Feller

14 September 2010

Rheem Australia Pty Ltd
112 Pilbara St
WELSPool WA 6106

Attention: Mr. Gary Gendall

Cardno (NSW) Pty Ltd
ABN 95 001 145 035

Level 3
Cardno Building
910 Pacific Highway
Gordon NSW 2072
Australia

Phone: 61 2 9496 7700
Fax: 61 2 9499 3902

www.cardno.com.au

Dear Gary,

RE: Solar Hot Water System Steel Framing System No. 022

The structural engineering analysis and design of the following solar hot water system support frame has been conducted by this firm:

Brand Name: Solahart

Product Description: 1 collector with pitch anti-cyclone frame 180 litre tank

Manufacturer's Name: Rheem Australia PTY LTD

Drawing No. 022 Rev. 1 dated 30/08/2010

We certify that this design is in accordance with normal engineering practice and principals and the relevant sections of the following Australian Standards:

- AS/NZS 1170.0:2002 Structural design actions – Part 0: General principles
- AS/NZS 1170.1:2002 Structural design actions – Part 1: Permanent, imposed and other actions
- AS/NZS 1170.2:2002 Structural design actions – Part 2: Wind Actions
- AS/NZS 4600:2005 Cold-formed steel structures
- AS 4100-1998 Steel structures
- AS/NZS 1664.1:1997 Aluminium structures Part 1: Limit state design
- AS 1720.1-1997 Timber structures Part 1: Design methods

The design of this support frame does not consider the effects of any snow or earthquake loading. In conjunction with AS/NZS 1170.2:2002 the frame has been designed to withstand wind loads up to and including region D, terrain category 2, installed at a maximum height of 10m (design wind speed 88m/s). This loading exceeds the requirements of Wind class N6/C4 when assessed in accordance with AS4055-2006 Wind loads for housing.

To achieve the structural design capacity, it is essential that the steel frame structure be constructed in a strict accordance with the fixing details provided by the manufacturer's specification.

It is noted that this certification relates to the design of the framing systems only, and that no structural assessment of water storage tanks or collector panels has been conducted. It is further noted that verification of the roofs capacity to withstand any additional loads imposed by the solar hot water system is outside of the scope of this certificate. No assessment has been made of any specific site as part of the design.

This certificate shall not be construed as relieving any other party of their legal responsibilities or contractual obligations.

Yours faithfully,



MARK HICKEY

Discipline Leader - Structures

for **Cardno (NSW)**

NT Certifying Engineer Reference # 32942ES

RPEQ # 1649

Our Ref: 605744-LO-40-031

Contact: Ryan Feller

14 September 2010

Rheem Australia Pty Ltd
112 Pilbara St
WELSPPOOL WA 6106

Attention: Mr. Gary Gendall

Cardno (NSW) Pty Ltd
ABN 95 001 145 035

Level 3
Cardno Building
910 Pacific Highway
Gordon NSW 2072
Australia

Phone: 61 2 9496 7700
Fax: 61 2 9499 3902

www.cardno.com.au

Dear Gary,

RE: Solar Hot Water System Steel Framing System No. 031

The structural engineering analysis and design of the following solar hot water system support frame has been conducted by this firm:

Brand Name: Solahart

Product Description: 2 collector with pitch anti-cyclone frame 180 litre tank

Manufacturer's Name: Rheem Australia PTY LTD

Drawing No. 031 Rev. 1 dated 30/08/2010

We certify that this design is in accordance with normal engineering practice and principals and the relevant sections of the following Australian Standards:

- AS/NZS 1170.0:2002 Structural design actions – Part 0: General principles
- AS/NZS 1170.1:2002 Structural design actions – Part 1: Permanent, imposed and other actions
- AS/NZS 1170.2:2002 Structural design actions – Part 2: Wind Actions
- AS/NZS 4600:2005 Cold-formed steel structures
- AS 4100-1998 Steel structures
- AS/NZS 1664.1:1997 Aluminium structures Part 1: Limit state design
- AS 1720.1-1997 Timber structures Part 1: Design methods

The design of this support frame does not consider the effects of any snow or earthquake loading. In conjunction with AS/NZS 1170.2:2002 the frame has been designed to withstand wind loads up to and including region D, terrain category 2, installed at a maximum height of 10m (design wind speed 88m/s). This loading exceeds the requirements of Wind class N6/C4 when assessed in accordance with AS4055-2006 Wind loads for housing.

To achieve the structural design capacity, it is essential that the steel frame structure be constructed in a strict accordance with the fixing details provided by the manufacturer's specification.

It is noted that this certification relates to the design of the framing systems only, and that no structural assessment of water storage tanks or collector panels has been conducted. It is further noted that verification of the roofs capacity to withstand any additional loads imposed by the solar hot water system is outside of the scope of this certificate. No assessment has been made of any specific site as part of the design.

This certificate shall not be construed as relieving any other party of their legal responsibilities or contractual obligations.

Yours faithfully,



MARK HICKEY

Discipline Leader - Structures

for **Cardno (NSW)**

NT Certifying Engineer Reference # 32942ES

RPEQ # 1649

Our Ref: 605744-LO-40-023

Contact: Ryan Feller

14 September 2010

Rheem Australia Pty Ltd
112 Pilbara St
WELSPOOL WA 6106

Attention: Mr. Gary Gendall

Cardno (NSW) Pty Ltd
ABN 95 001 145 035

Level 3
Cardno Building
910 Pacific Highway
Gordon NSW 2072
Australia

Phone: 61 2 9496 7700
Fax: 61 2 9499 3902

www.cardno.com.au

Dear Gary,

RE: Solar Hot Water System Steel Framing System No. 023

The structural engineering analysis and design of the following solar hot water system support frame has been conducted by this firm:

Brand Name: Solahart

Product Description: 1 collector with pitch anti-cyclone frame 220 litre tank

Manufacturer's Name: Rheem Australia PTY LTD

Drawing No. 023 Rev. 1 dated 30/08/2010

We certify that this design is in accordance with normal engineering practice and principals and the relevant sections of the following Australian Standards:

- AS/NZS 1170.0:2002 Structural design actions – Part 0: General principles
- AS/NZS 1170.1:2002 Structural design actions – Part 1: Permanent, imposed and other actions
- AS/NZS 1170.2:2002 Structural design actions – Part 2: Wind Actions
- AS/NZS 4600:2005 Cold-formed steel structures
- AS 4100-1998 Steel structures
- AS/NZS 1664.1:1997 Aluminium structures Part 1: Limit state design
- AS 1720.1-1997 Timber structures Part 1: Design methods

The design of this support frame does not consider the effects of any snow or earthquake loading. In conjunction with AS/NZS 1170.2:2002 the frame has been designed to withstand wind loads up to and including region D, terrain category 2, installed at a maximum height of 10m (design wind speed 88m/s). This loading exceeds the requirements of Wind class N6/C4 when assessed in accordance with AS4055-2006 Wind loads for housing.

To achieve the structural design capacity, it is essential that the steel frame structure be constructed in a strict accordance with the fixing details provided by the manufacturer's specification.

It is noted that this certification relates to the design of the framing systems only, and that no structural assessment of water storage tanks or collector panels has been conducted. It is further noted that verification of the roofs capacity to withstand any additional loads imposed by the solar hot water system is outside of the scope of this certificate. No assessment has been made of any specific site as part of the design.

This certificate shall not be construed as relieving any other party of their legal responsibilities or contractual obligations.

Yours faithfully,



MARK HICKEY
Discipline Leader - Structures
for **Cardno (NSW)**
NT Certifying Engineer Reference # 32942ES
RPEQ # 1649

Our Ref: 605744-LO-40-032

Contact: Ryan Feller

14 September 2010

Rheem Australia Pty Ltd
112 Pilbara St
WELSPool WA 6106

Attention: Mr. Gary Gendall

Cardno (NSW) Pty Ltd
ABN 95 001 145 035

Level 3
Cardno Building
910 Pacific Highway
Gordon NSW 2072
Australia

Phone: 61 2 9496 7700
Fax: 61 2 9499 3902

www.cardno.com.au

Dear Gary,

RE: Solar Hot Water System Steel Framing System No. 032

The structural engineering analysis and design of the following solar hot water system support frame has been conducted by this firm:

Brand Name: Solahart

Product Description: 2 collector with pitch anti-cyclone frame 220 litre tank

Manufacturer's Name: Rheem Australia PTY LTD

Drawing No. 032 Rev. 1 dated 30/08/2010

We certify that this design is in accordance with normal engineering practice and principals and the relevant sections of the following Australian Standards:

- AS/NZS 1170.0:2002 Structural design actions – Part 0: General principles
- AS/NZS 1170.1:2002 Structural design actions – Part 1: Permanent, imposed and other actions
- AS/NZS 1170.2:2002 Structural design actions – Part 2: Wind Actions
- AS/NZS 4600:2005 Cold-formed steel structures
- AS 4100-1998 Steel structures
- AS/NZS 1664.1:1997 Aluminium structures Part 1: Limit state design
- AS 1720.1-1997 Timber structures Part 1: Design methods

The design of this support frame does not consider the effects of any snow or earthquake loading. In conjunction with AS/NZS 1170.2:2002 the frame has been designed to withstand wind loads up to and including region D, terrain category 2, installed at a maximum height of 10m (design wind speed 88m/s). This loading exceeds the requirements of Wind class N6/C4 when assessed in accordance with AS4055-2006 Wind loads for housing.

To achieve the structural design capacity, it is essential that the steel frame structure be constructed in a strict accordance with the fixing details provided by the manufacturer's specification.

It is noted that this certification relates to the design of the framing systems only, and that no structural assessment of water storage tanks or collector panels has been conducted. It is further noted that verification of the roofs capacity to withstand any additional loads imposed by the solar hot water system is outside of the scope of this certificate. No assessment has been made of any specific site as part of the design.

This certificate shall not be construed as relieving any other party of their legal responsibilities or contractual obligations.

Yours faithfully,



MARK HICKEY
Discipline Leader - Structures
for **Cardno (NSW)**
NT Certifying Engineer Reference # 32942ES
RPEQ # 1649

Our Ref: 605744-LO-40-033

Contact: Ryan Feller

14 September 2010

Rheem Australia Pty Ltd
112 Pilbara St
WELSPPOOL WA 6106

Attention: Mr. Gary Gendall

Dear Gary,

RE: Solar Hot Water System Steel Framing System No. 033

The structural engineering analysis and design of the following solar hot water system support frame has been conducted by this firm:

Brand Name: Solahart

Product Description: 2 collector with pitch anti-cyclone frame 300 litre tank

Manufacturer's Name: Rheem Australia PTY LTD

Drawing No. 033 Rev. 1 dated 30/08/2010

We certify that this design is in accordance with normal engineering practice and principals and the relevant sections of the following Australian Standards:

- AS/NZS 1170.0:2002 Structural design actions – Part 0: General principles
- AS/NZS 1170.1:2002 Structural design actions – Part 1: Permanent, imposed and other actions
- AS/NZS 1170.2:2002 Structural design actions – Part 2: Wind Actions
- AS/NZS 4600:2005 Cold-formed steel structures
- AS 4100-1998 Steel structures
- AS/NZS 1664.1:1997 Aluminium structures Part 1: Limit state design
- AS 1720.1-1997 Timber structures Part 1: Design methods

The design of this support frame does not consider the effects of any snow or earthquake loading. In conjunction with AS/NZS 1170.2:2002 the frame has been designed to withstand wind loads up to and including region D, terrain category 2, installed at a maximum height of 10m (design wind speed 88m/s). This loading exceeds the requirements of Wind class N6/C4 when assessed in accordance with AS4055-2006 Wind loads for housing.

Cardno (NSW) Pty Ltd
ABN 95 001 145 035

Level 3
Cardno Building
910 Pacific Highway
Gordon NSW 2072
Australia

Phone: 61 2 9496 7700
Fax: 61 2 9499 3902

www.cardno.com.au

To achieve the structural design capacity, it is essential that the steel frame structure be constructed in a strict accordance with the fixing details provided by the manufacturer's specification.

It is noted that this certification relates to the design of the framing systems only, and that no structural assessment of water storage tanks or collector panels has been conducted. It is further noted that verification of the roofs capacity to withstand any additional loads imposed by the solar hot water system is outside of the scope of this certificate. No assessment has been made of any specific site as part of the design.

This certificate shall not be construed as relieving any other party of their legal responsibilities or contractual obligations.

Yours faithfully,



MARK HICKEY

Discipline Leader - Structures

for **Cardno (NSW)**

NT Certifying Engineer Reference # 32942ES

RPEQ # 1649

Our Ref: 605744-LO-45-041

Contact: Ryan Feller

18 October 2010

Rheem Australia Pty Ltd
112 Pilbara St
WELSPOOL WA 6106

Attention: Mr. Gary Gendall

Cardno (NSW) Pty Ltd
ABN 95 001 145 035

Level 3
Cardno Building
910 Pacific Highway
Gordon NSW 2072
Australia

Phone: 61 2 9496 7700
Fax: 61 2 9499 3902

www.cardno.com.au

Dear Gary,

RE: Solar Hot Water Support Frame No. 041

The structural engineering analysis and design of the following solar hot water system support frame has been conducted by this firm:

Brand Name: Solahart

Product Description: 3 collector with pitch anti-cyclone frame 300 litre tank

Manufacturer's Name: Rheem Australia PTY LTD

Drawing No. 041 Rev. 1 dated 07/10/2010

We certify that this design is in accordance with normal engineering practice and principals and the relevant sections of the following Australian Standards:

- AS/NZS 1170.0:2002 Structural design actions – Part 0: General principles
- AS/NZS 1170.1:2002 Structural design actions – Part 1: Permanent, imposed and other actions
- AS/NZS 1170.2:2002 Structural design actions – Part 2: Wind Actions
- AS/NZS 4600:2005 Cold-formed steel structures
- AS 4100-1998 Steel structures
- AS/NZS 1664.1:1997 Aluminium structures Part 1: Limit state design
- AS 1720.1-1997 Timber structures Part 1: Design methods

The design of this support frame does not consider the effects of any snow or earthquake loading. In conjunction with AS/NZS 1170.2:2002 the frame has been designed to withstand wind loads up to and including region D, terrain category 2, installed at a maximum height of 10m (design wind speed 88m/s). This loading exceeds the requirements of Wind class N6/C4 when assessed in accordance with AS4055-2006 Wind loads for housing.

To achieve the structural design capacity, it is essential that the steel frame structure be constructed in a strict accordance with the fixing details provided by the manufacturer's specification.

It is noted that this certification relates to the design of the framing systems only, and that no structural assessment of water storage tanks or collector panels has been conducted. It is further noted that verification of the roofs capacity to withstand any additional loads imposed by the solar hot water system is outside of the scope of this certificate.

This certificate shall not be construed as relieving any other party of their legal responsibilities or contractual obligations.

Yours faithfully,



MARK HICKEY

Discipline Leader - Structures

for **Cardno (NSW)**

NT Certifying Engineer Reference # 32942ES

RPEQ # 01649

Our Ref: 605744-LO-45-042

Contact: Ryan Feller

18 October 2010

Rheem Australia Pty Ltd
112 Pilbara St
WELSPOOL WA 6106

Attention: Mr. Gary Gendall

Cardno (NSW) Pty Ltd
ABN 95 001 145 035

Level 3
Cardno Building
910 Pacific Highway
Gordon NSW 2072
Australia

Phone: 61 2 9496 7700
Fax: 61 2 9499 3902

www.cardno.com.au

Dear Gary,

RE: Solar Hot Water Support Frame No. 042

The structural engineering analysis and design of the following solar hot water system support frame has been conducted by this firm:

Brand Name: Solahart

Product Description: 3 collector with pitch anti-cyclone frame 440 litre tank

Manufacturer's Name: Rheem Australia PTY LTD

Drawing No. 042 Rev. 1 dated 11/10/2010

We certify that this design is in accordance with normal engineering practice and principals and the relevant sections of the following Australian Standards:

- AS/NZS 1170.0:2002 Structural design actions – Part 0: General principles
- AS/NZS 1170.1:2002 Structural design actions – Part 1: Permanent, imposed and other actions
- AS/NZS 1170.2:2002 Structural design actions – Part 2: Wind Actions
- AS/NZS 4600:2005 Cold-formed steel structures
- AS 4100-1998 Steel structures
- AS/NZS 1664.1:1997 Aluminium structures Part 1: Limit state design
- AS 1720.1-1997 Timber structures Part 1: Design methods

The design of this support frame does not consider the effects of any snow or earthquake loading. In conjunction with AS/NZS 1170.2:2002 the frame has been designed to withstand wind loads up to and including region D, terrain category 2, installed at a maximum height of 10m (design wind speed 88m/s). This loading exceeds the requirements of Wind class N6/C4 when assessed in accordance with AS4055-2006 Wind loads for housing.

To achieve the structural design capacity, it is essential that the steel frame structure be constructed in a strict accordance with the fixing details provided by the manufacturer's specification.

It is noted that this certification relates to the design of the framing systems only, and that no structural assessment of water storage tanks or collector panels has been conducted. It is further noted that verification of the roofs capacity to withstand any additional loads imposed by the solar hot water system is outside of the scope of this certificate.

This certificate shall not be construed as relieving any other party of their legal responsibilities or contractual obligations.

Yours faithfully,



MARK HICKEY
Discipline Leader - Structures
for **Cardno (NSW)**
NT Certifying Engineer Reference # 32942ES
RPEQ # 01649

Our Ref: 605744-LO-45-046

Contact: Ryan Feller

18 October 2010

Rheem Australia Pty Ltd
112 Pilbara St
WELSPOOL WA 6106

Attention: Mr. Gary Gendall

Dear Gary,

RE: Solar Hot Water Support Frame No. 046

The structural engineering analysis and design of the following solar hot water system support frame has been conducted by this firm:

Brand Name: Solahart

Product Description: 4 collector with pitch anti-cyclone frame 440 litre tank

Manufacturer's Name: Rheem Australia PTY LTD

Drawing No. 046 Rev. 1 dated 11/10/2010

We certify that this design is in accordance with normal engineering practice and principals and the relevant sections of the following Australian Standards:

- AS/NZS 1170.0:2002 Structural design actions – Part 0: General principles
- AS/NZS 1170.1:2002 Structural design actions – Part 1: Permanent, imposed and other actions
- AS/NZS 1170.2:2002 Structural design actions – Part 2: Wind Actions
- AS/NZS 4600:2005 Cold-formed steel structures
- AS 4100-1998 Steel structures
- AS/NZS 1664.1:1997 Aluminium structures Part 1: Limit state design
- AS 1720.1-1997 Timber structures Part 1: Design methods

The design of this support frame does not consider the effects of any snow or earthquake loading. In conjunction with AS/NZS 1170.2:2002 the frame has been designed to withstand wind loads up to and including region D, terrain category 2, installed at a maximum height of 10m (design wind speed 88m/s). This loading exceeds the requirements of Wind class N6/C4 when assessed in accordance with AS4055-2006 Wind loads for housing.

Cardno (NSW) Pty Ltd
ABN 95 001 145 035

Level 3
Cardno Building
910 Pacific Highway
Gordon NSW 2072
Australia

Phone: 61 2 9496 7700
Fax: 61 2 9499 3902

www.cardno.com.au

To achieve the structural design capacity, it is essential that the steel frame structure be constructed in a strict accordance with the fixing details provided by the manufacturer's specification.

It is noted that this certification relates to the design of the framing systems only, and that no structural assessment of water storage tanks or collector panels has been conducted. It is further noted that verification of the roofs capacity to withstand any additional loads imposed by the solar hot water system is outside of the scope of this certificate.

This certificate shall not be construed as relieving any other party of their legal responsibilities or contractual obligations.

Yours faithfully,



MARK HICKEY
Discipline Leader - Structures
for **Cardno (NSW)**
NT Certifying Engineer Reference # 32942ES
RPEQ # 01649

Our Ref: 605744-LO-43-027

Contact: Ryan Feller

8 October 2010

Rheem Australia Pty Ltd
112 Pilbara St
WELSPPOOL WA 6106

Attention: Mr. Gary Gendall

Dear Gary,

RE: Solar Hot Water Support Frame No. 027

The structural engineering analysis and design of the following solar hot water system support frame has been conducted by this firm:

Brand Name: Sunheat

Product Description: 1 collector with pitch anti-cyclone frame 160 litre tank

Manufacturer's Name: Rheem Australia PTY LTD

Drawing No. 024 Rev. 2 dated 15/09/2010

We certify that this design is in accordance with normal engineering practice and principals and the relevant sections of the following Australian Standards:

- AS/NZS 1170.0:2002 Structural design actions – Part 0: General principles
- AS/NZS 1170.1:2002 Structural design actions – Part 1: Permanent, imposed and other actions
- AS/NZS 1170.2:2002 Structural design actions – Part 2: Wind Actions
- AS/NZS 4600:2005 Cold-formed steel structures
- AS 4100-1998 Steel structures
- AS/NZS 1664.1:1997 Aluminium structures Part 1: Limit state design
- AS 1720.1-1997 Timber structures Part 1: Design methods

The design of this support frame does not consider the effects of any snow or earthquake loading. In conjunction with AS/NZS 1170.2:2002 the frame has been designed to withstand wind loads up to and including region D, terrain category 2, installed at a maximum height of 10m (design wind speed 88m/s). This loading exceeds the requirements of Wind class N6/C4 when assessed in accordance with AS4055-2006 Wind loads for housing.

Cardno (NSW) Pty Ltd
ABN 95 001 145 035

Level 3
Cardno Building
910 Pacific Highway
Gordon NSW 2072
Australia

Phone: 61 2 9496 7700
Fax: 61 2 9499 3902

www.cardno.com.au

To achieve the structural design capacity, it is essential that the steel frame structure be constructed in a strict accordance with the fixing details provided by the manufacturer's specification.

It is noted that this certification relates to the design of the framing systems only, and that no structural assessment of water storage tanks or collector panels has been conducted. It is further noted that verification of the roofs capacity to withstand any additional loads imposed by the solar hot water system is outside of the scope of this certificate.

This certificate shall not be construed as relieving any other party of their legal responsibilities or contractual obligations.

Yours faithfully,

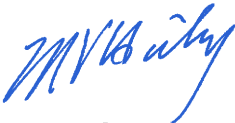

MARK HICKEY
Discipline Leader - Structures
for Cardno (NSW)
NT Certifying Engineer Reference # 32942ES
RPEQ # 01649

Our Ref: 605744-LO-40-028

Contact: Ryan Feller

14 September 2010

Rheem Australia Pty Ltd
112 Pilbara St
WELSPPOOL WA 6106

Attention: Mr. Gary Gendall

Cardno (NSW) Pty Ltd
ABN 95 001 145 035

Level 3
Cardno Building
910 Pacific Highway
Gordon NSW 2072
Australia

Phone: 61 2 9496 7700
Fax: 61 2 9499 3902

www.cardno.com.au

Dear Gary,

RE: Solar Hot Water System Steel Framing System No. 028

The structural engineering analysis and design of the following solar hot water system support frame has been conducted by this firm:

Brand Name: Sunheat

Product Description: 1 collector with pitch anti-cyclone frame 180 litre tank

Manufacturer's Name: Rheem Australia PTY LTD

Drawing No. 028 Rev. 1 dated 30/08/2010

We certify that this design is in accordance with normal engineering practice and principals and the relevant sections of the following Australian Standards:

- AS/NZS 1170.0:2002 Structural design actions – Part 0: General principles
- AS/NZS 1170.1:2002 Structural design actions – Part 1: Permanent, imposed and other actions
- AS/NZS 1170.2:2002 Structural design actions – Part 2: Wind Actions
- AS/NZS 4600:2005 Cold-formed steel structures
- AS 4100-1998 Steel structures
- AS/NZS 1664.1:1997 Aluminium structures Part 1: Limit state design
- AS 1720.1-1997 Timber structures Part 1: Design methods

The design of this support frame does not consider the effects of any snow or earthquake loading. In conjunction with AS/NZS 1170.2:2002 the frame has been designed to withstand wind loads up to and including region D, terrain category 2, installed at a maximum height of 10m (design wind speed 88m/s). This loading exceeds the requirements of Wind class N6/C4 when assessed in accordance with AS4055-2006 Wind loads for housing.

To achieve the structural design capacity, it is essential that the steel frame structure be constructed in a strict accordance with the fixing details provided by the manufacturer's specification.

It is noted that this certification relates to the design of the framing systems only, and that no structural assessment of water storage tanks or collector panels has been conducted. It is further noted that verification of the roofs capacity to withstand any additional loads imposed by the solar hot water system is outside of the scope of this certificate. No assessment has been made of any specific site as part of the design.

This certificate shall not be construed as relieving any other party of their legal responsibilities or contractual obligations.

Yours faithfully,



MARK HICKEY

Discipline Leader - Structures

for **Cardno (NSW)**

NT Certifying Engineer Reference # 32942ES

RPEQ # 1649

Our Ref: 605744-LO-43-038

Contact: Ryan Feller

8 October 2010

Rheem Australia Pty Ltd
112 Pilbara St
WELSPOOL WA 6106

Attention: Mr. Gary Gendall

Cardno (NSW) Pty Ltd
ABN 95 001 145 035

Level 3
Cardno Building
910 Pacific Highway
Gordon NSW 2072
Australia

Phone: 61 2 9496 7700
Fax: 61 2 9499 3902

www.cardno.com.au

Dear Gary,

RE: Solar Hot Water Support Frame No. 038

The structural engineering analysis and design of the following solar hot water system support frame has been conducted by this firm:

Brand Name: Sunheat

Product Description: 2 collector with pitch anti-cyclone frame 300 litre tank

Manufacturer's Name: Rheem Australia PTY LTD

Drawing No. 034 Rev. 2 dated 15/09/2010

We certify that this design is in accordance with normal engineering practice and principals and the relevant sections of the following Australian Standards:

- AS/NZS 1170.0:2002 Structural design actions – Part 0: General principles
- AS/NZS 1170.1:2002 Structural design actions – Part 1: Permanent, imposed and other actions
- AS/NZS 1170.2:2002 Structural design actions – Part 2: Wind Actions
- AS/NZS 4600:2005 Cold-formed steel structures
- AS 4100-1998 Steel structures
- AS/NZS 1664.1:1997 Aluminium structures Part 1: Limit state design
- AS 1720.1-1997 Timber structures Part 1: Design methods

The design of this support frame does not consider the effects of any snow or earthquake loading. In conjunction with AS/NZS 1170.2:2002 the frame has been designed to withstand wind loads up to and including region D, terrain category 2, installed at a maximum height of 10m (design wind speed 88m/s). This loading exceeds the requirements of Wind class N6/C4 when assessed in accordance with AS4055-2006 Wind loads for housing.

To achieve the structural design capacity, it is essential that the steel frame structure be constructed in a strict accordance with the fixing details provided by the manufacturer's specification.

It is noted that this certification relates to the design of the framing systems only, and that no structural assessment of water storage tanks or collector panels has been conducted. It is further noted that verification of the roofs capacity to withstand any additional loads imposed by the solar hot water system is outside of the scope of this certificate.

This certificate shall not be construed as relieving any other party of their legal responsibilities or contractual obligations.

Yours faithfully,



MARK HICKEY
Discipline Leader - Structures
for Cardno (NSW)
NT Certifying Engineer Reference # 32942ES
RPEQ # 01649

Our Ref: 605744-LO-40-039

Contact: Ryan Feller

14 September 2010

Rheem Australia Pty Ltd
112 Pilbara St
WELSPOOL WA 6106

Attention: Mr. Gary Gendall

Dear Gary,

Cardno (NSW) Pty Ltd
ABN 95 001 145 035

Level 3
Cardno Building
910 Pacific Highway
Gordon NSW 2072
Australia

Phone: 61 2 9496 7700
Fax: 61 2 9499 3902

www.cardno.com.au

RE: Solar Hot Water System Steel Framing System No. 039

The structural engineering analysis and design of the following solar hot water system support frame has been conducted by this firm:

Brand Name: Sunheat

Product Description: 2 collector with pitch anti-cyclone frame 300 litre tank

Manufacturer's Name: Rheem Australia PTY LTD

Drawing No. 039 Rev. 1 dated 30/08/2010

We certify that this design is in accordance with normal engineering practice and principals and the relevant sections of the following Australian Standards:

- AS/NZS 1170.0:2002 Structural design actions – Part 0: General principles
- AS/NZS 1170.1:2002 Structural design actions – Part 1: Permanent, imposed and other actions
- AS/NZS 1170.2:2002 Structural design actions – Part 2: Wind Actions
- AS/NZS 4600:2005 Cold-formed steel structures
- AS 4100-1998 Steel structures
- AS/NZS 1664.1:1997 Aluminium structures Part 1: Limit state design
- AS 1720.1-1997 Timber structures Part 1: Design methods

The design of this support frame does not consider the effects of any snow or earthquake loading. In conjunction with AS/NZS 1170.2:2002 the frame has been designed to withstand wind loads up to and including region D, terrain category 2, installed at a maximum height of 10m (design wind speed 88m/s). This loading exceeds the requirements of Wind class N6/C4 when assessed in accordance with AS4055-2006 Wind loads for housing.

To achieve the structural design capacity, it is essential that the steel frame structure be constructed in a strict accordance with the fixing details provided by the manufacturer's specification.

It is noted that this certification relates to the design of the framing systems only, and that no structural assessment of water storage tanks or collector panels has been conducted. It is further noted that verification of the roofs capacity to withstand any additional loads imposed by the solar hot water system is outside of the scope of this certificate. No assessment has been made of any specific site as part of the design.

This certificate shall not be construed as relieving any other party of their legal responsibilities or contractual obligations.

Yours faithfully,



MARK HICKEY
Discipline Leader - Structures
for **Cardno (NSW)**
NT Certifying Engineer Reference # 32942ES
RPEQ # 1649

This page is intentionally blank.

This page is intentionally blank.

This page is intentionally blank.
