

NOTE:  
WALL & ROOF PANELS  
TO BE SHOWN AS PER  
FUNCTION AS SHEAR  
DIAPHRAGMS

**Roof Framing Plan**  
1/4" = 1'-0"

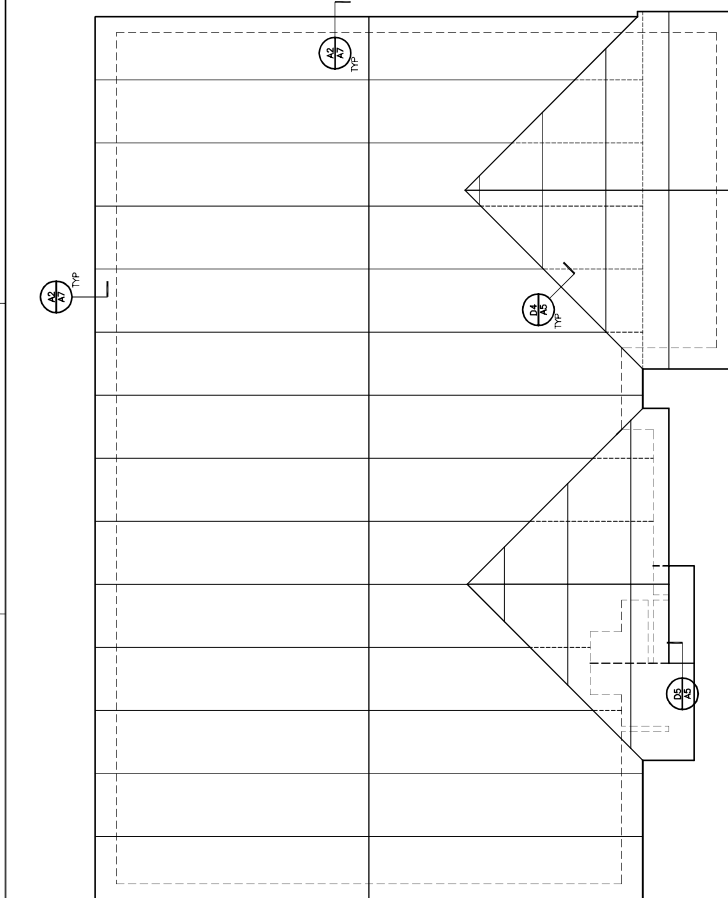

NOTE:  
WALL & ROOF PANELS  
TO BE SHOWN AS PER  
FUNCTION AS SHEAR  
DIAPHRAGMS

**Roof Panel Plan**  
1/4" = 1'-0"

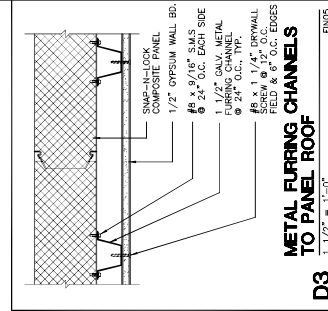

**D3** 1 1/2" = 1'-0"

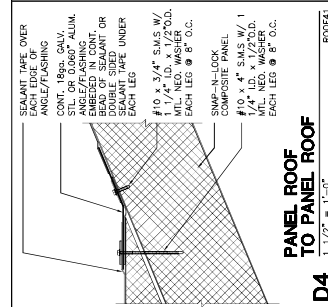

**D4** 1 1/2" = 1'-0"

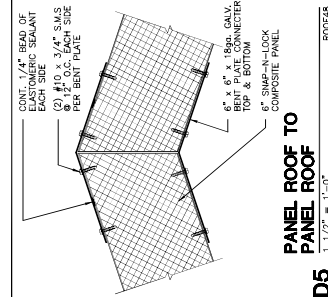

**D5** 1 1/2" = 1'-0"

**ROOF#8**

**The Cameron**  
**Steel Snap-N-Lock Panel House**  
**1809 SF, 1 Story, 3 Bedm, 2 Bath, 2 Car Garage**  
**Standard Model**

Project No. 03-14-03  
Date: JRD  
Drawn:  
Revised:

© 2003 S.B.S., INC.

**A5**





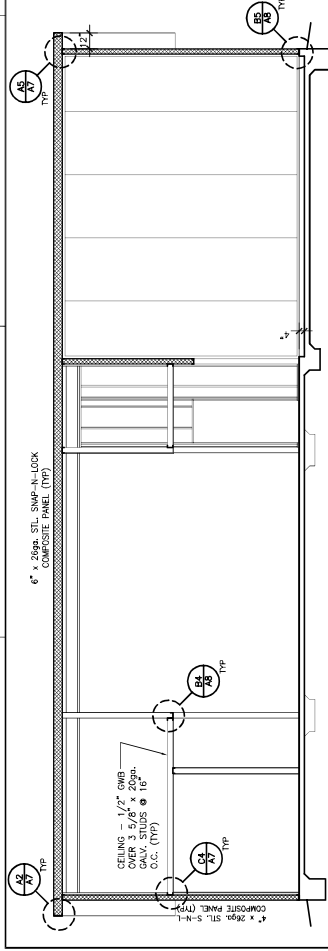

**Section A**  
1/4" = 1'-0"

- NOTES:  
1. WALL & ROOF PANELS SHALL BE INSTALLED TO FUNCTION AS SHEAR DIAPHRAGMS.  
2. PROVIDE FIRE BLOCKING AT ALL WALL PENETRATIONS. ALL WALLS FINISH ABOVE CEILING (TYP)

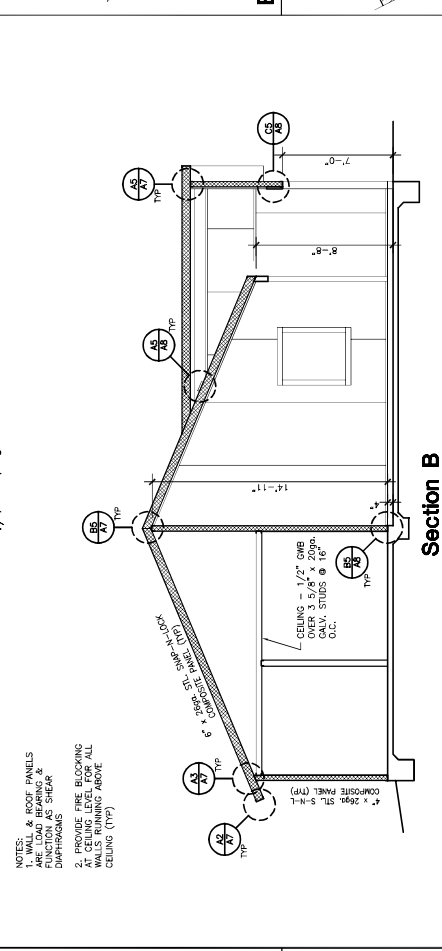

**Section B**  
1/4" = 1'-0"

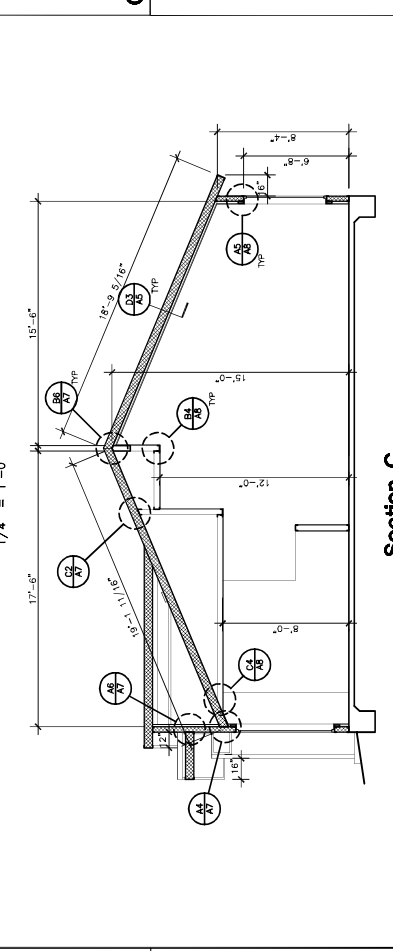

**Section C**  
1/4" = 1'-0"

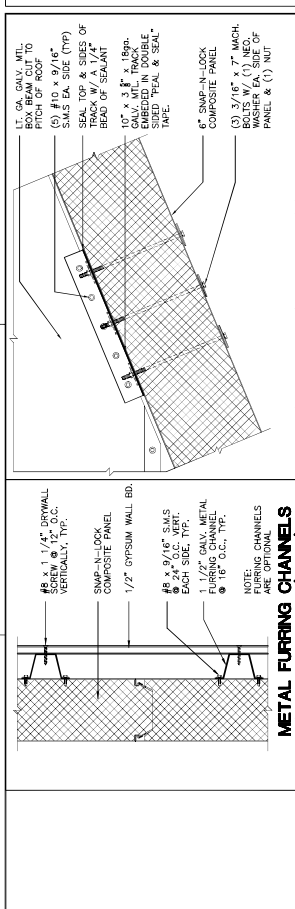

**A4** 1 1/2" = 1'-0"

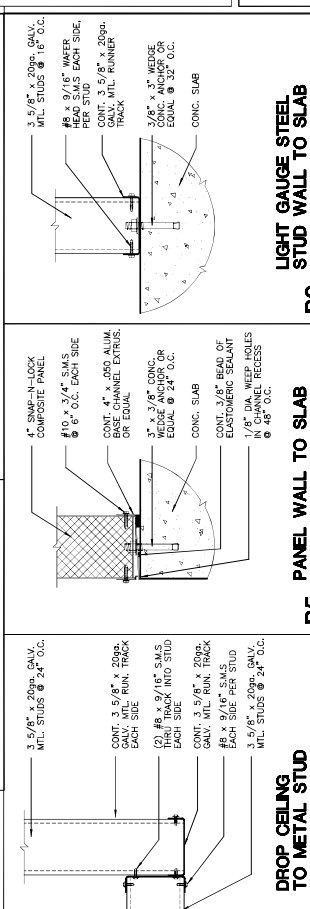

**B4** 1 1/2" = 1'-0"

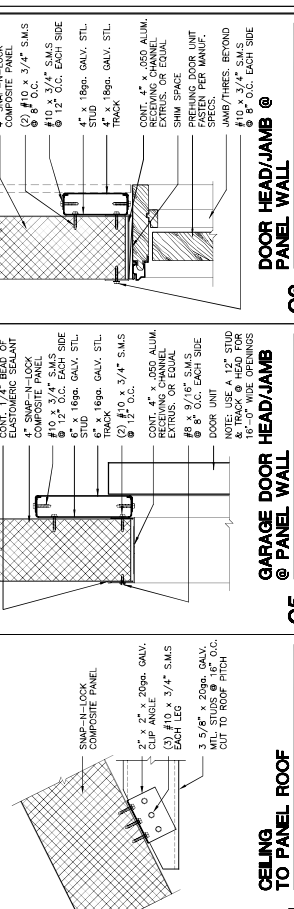

**B5** 1 1/2" = 1'-0"

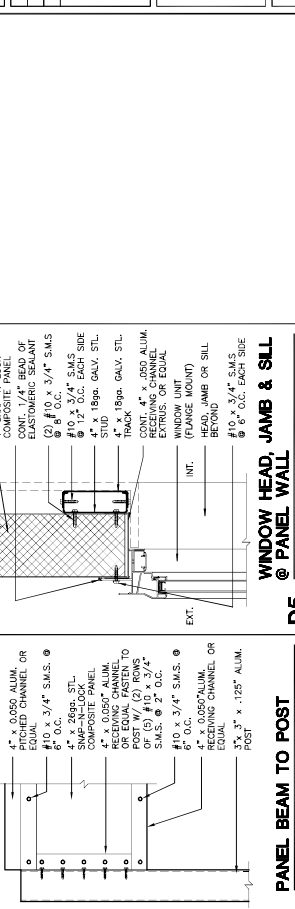

**C4** 1 1/2" = 1'-0"

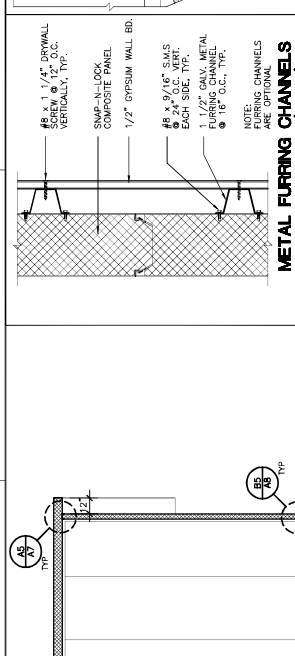

**A5** 1 1/2" = 1'-0"

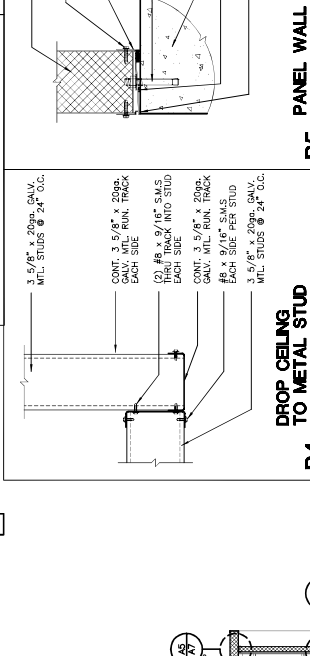

**B6** 1 1/2" = 1'-0"

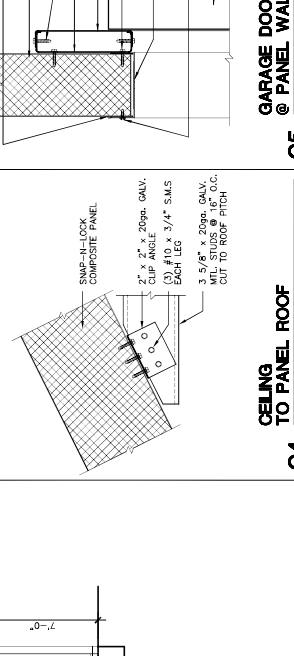

**C5** 1 1/2" = 1'-0"

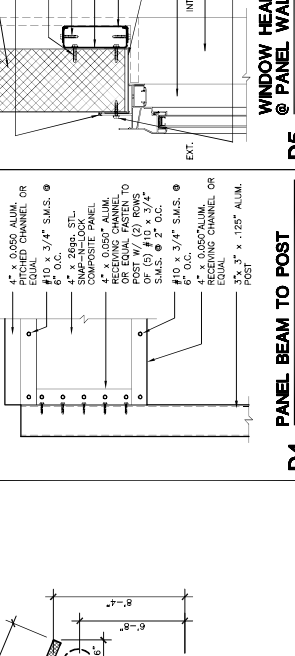

**D5** 1 1/2" = 1'-0"

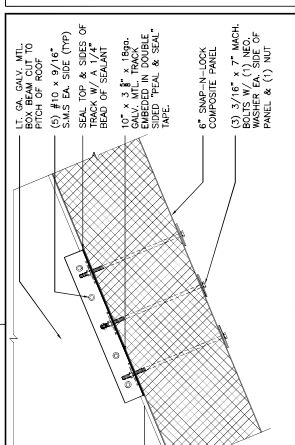

**A8**

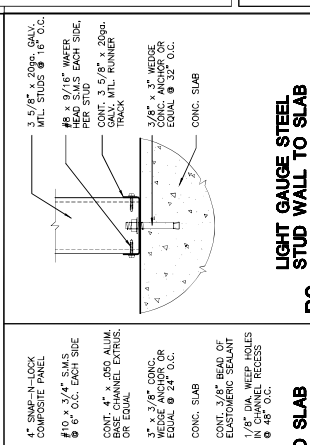

**B6** 1 1/2" = 1'-0"

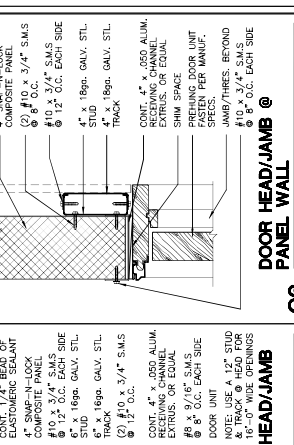

**C6** 1 1/2" = 1'-0"

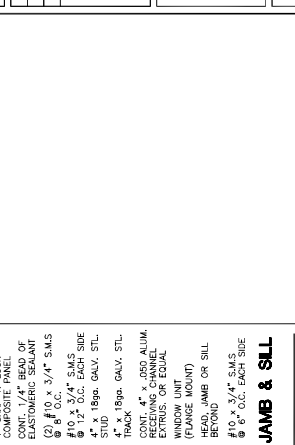

**D5** 1 1/2" = 1'-0"

**The Cameron Steel Snap-N-Lock Panel House**  
1809 SF, 1 Story, 3 Bedm, 2 Bath, 2 Car Garage  
Standard Model

Project No. 03-14-03  
Date: JRD  
Revised:

© 2003 S.B.S., INC.