

ProgressivTube[®]

Passive Solar Water Heater

INSTALLATION and OPERATIONS MANUAL



Manufacturer of Solar Thermal Equipment

Table of Contents

I. Introduction	3	XII. Freeze Prevention	18
II. Utilization	3	XIII. Two or More Collector Systems	18
III. System Characteristics	5	XIV. Direct Systems	20
IV. Pre-Installation Check List	5	XV. Start Up Procedures	21
V. Installation Precautions	5	XVI. Drain Procedures	22
VI. Collector Orientation	6	XVII. Maintenance and Operation	22
VII. Collector Mounting Hardware Options	6	APPENDIX	
VIII. Roof Mounts	6	SRCC Section	23
IX. Ground Mounts	13	FSEC Section	27
X. System Plumbing	13	INSTALLATION DETAILS	29
XI. System Insulation	16	TYPICAL ROOF BRACING	37

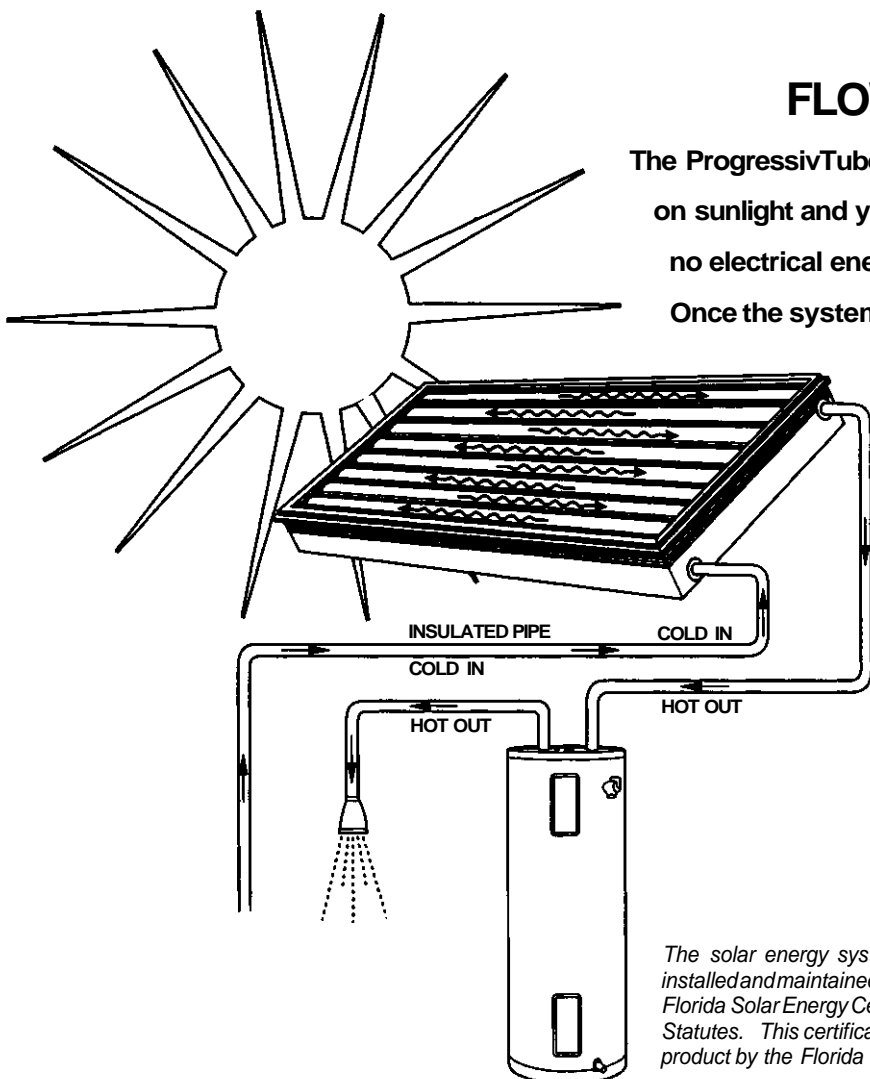

FLOW PATTERN

The ProgressivTube® solar water heater works simply on sunlight and your local water pressure. There is no electrical energy needed to make it function.

Once the system has been filled, it will operate on

the pressure or flow rates that are normal to your household. The uncomplicated design and quality construction of the solar collector will provide you with years of energy-saving, trouble-free operation.

The solar energy systems described by this manual, when properly installed and maintained, meet the minimum standards established by the Florida Solar Energy Center, in accordance with Section 377.705, Florida Statutes. This certification does not imply endorsement or warranty of the product by the Florida Solar Energy Center or the State of Florida.

PROGRESSIVTUBE® INSTALLATION MANUAL

I. INTRODUCTION

This installation manual is intended to provide the requirements, recommendations, and guidelines necessary to achieve a fast installation and years of trouble-free system operation. There are many ways to plumb a Progressivtube system but only the methods included in this manual are endorsed by the manufacturer. The pre-heater system designs in this manual meet the Florida Solar Energy Center's (FSEC) Approved Systems review and certification program, and/or the Solar Ratings and Certification Corporation's (SRCC) Certified Solar Collector and Water Heating System Rating and Standards program. All ProgressivTube models have an approved listing by the International Association of Plumbing and Mechanical Officials (IAPMO).

The FSEC Approved Systems are called "two-way systems" and the proper plumbing schematic should be followed depending upon whether a conventional gas or electric water heater is used for back-up. A **"two-way" system** is one in which a system can function in one of two ways; either as a solar pre-heater to the conventional gas or electric water heater or as a conventional water heater only with the ProgressivTube unit being by-passed.

The SRCC certified OG 300 system is a **"three-way" system** designed for use with either a gas or electric conventional water heater. A "three-way" system can function in any of the three following modes: solar pre-heat, solar by-pass, or solar direct. The solar direct mode feeds solar heated water directly to the household from the ProgressivTube unit allowing the conventional water heater to be

by-passed and turned off. This mode allows homeowners to maximize their savings during peak solar collecting months, usually spring through fall. To meet all requirements of the SRCC OG 300 system, please refer to the SRCC section in the Appendix.

In low latitude areas of the world, such as the Caribbean and Southeast Asia, a ProgressivTube system is usually installed as a **Direct System**. This system design has minimum plumbing requirements and does not have a back-up conventional water heater. Direct Systems do not have FSEC or SRCC system certifications. However, all ProgressivTube models do have FSEC performance certification. Consult the "Direct Systems" section in this manual for specific information on this system design.

The procedures in this manual are for all ProgressivTube Passive Solar Water Heater models. The only difference in the five available models is the amount of water each one holds: PT-18-CN, 18 gallons; PT-30-CN, 30 gallons; PT-35-CN, 35 gallons; PT-40-CN, 41 gallons; PT-50-CN, 51 gallons. All models have a 30-year design life. For additional warranty information please contact our manufacturing office by mail at *P.O. Box 3887, Sarasota, Florida 34230-3887* or by phone at *941-953-2177* or fax at *941-957-0106*.

II. UTILIZATION

ProgressivTube Passive Solar Water Heaters are designed as self-contained units that act as a solar collector and storage tank integrated into one piece of equipment. In most cases, they are utilized as a pre-heater to a conventional water heater;

however, they can be installed as direct solar water heaters. The unit can also be used as a pre-heater for a terminal or instantaneous water heater. If a ProgressivTube unit is installed to a terminal or instantaneous water heater the procedures and plumbing schematics for either the two way or three way system should be followed. Make certain the instantaneous water heater has a temperature limiting device. Many electric models do not include this safety device and should be avoided. Note: systems plumbed to a terminal or instantaneous water heater do not have FSEC or SRCC certifications.

ProgressivTube systems are designed to operate automatically. However, as with all solar water heating systems, the total amount of solar contribution by the system is dependent upon the hot water consumption pattern of the household, daily weather conditions, and variable amounts of available sunlight throughout the year. Energy savings will vary from month to month, but it is possible to maximize these savings by scheduling large hot water usage, such as clothes and dishwashing, for the early afternoon.

The simple design and quality construction of the ProgressivTube will ensure a reliable service life of thirty years or more. This manual details the essential operation of the system and is intended to illustrate proper installation techniques. To ensure trouble-free operation, all installation work should be performed by qualified licensed contractors and in accordance with all local codes.

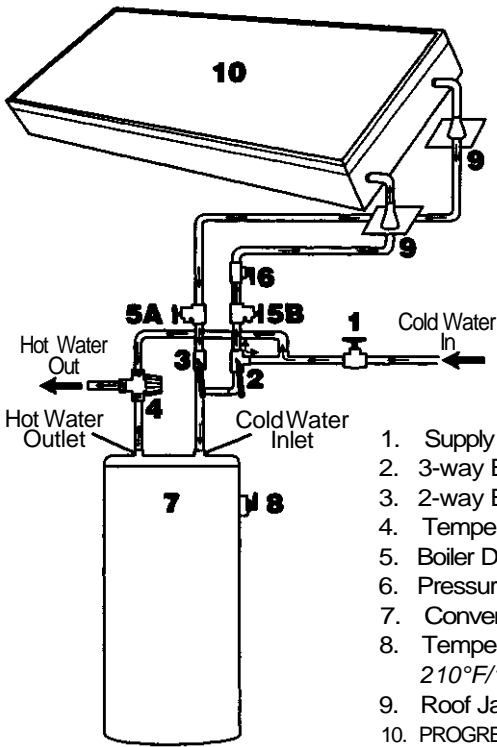

**2-WAY SYSTEM
FOR ELECTRIC WATER HEATERS**

1. Supply shut off valve
2. 3-way Ball Valve: *Bronze*
3. 2-way Ball Valve: *Bronze*
4. Tempering Valve
5. Boiler Drains: *Bronze*
6. Pressure Relief Valve: *150 psi*
7. Conventional Water Heater
8. Temperature/Pressure Relief Valve: *210°F/150psi*
9. Roof Jacks
10. PROGRESSIVTUBE®

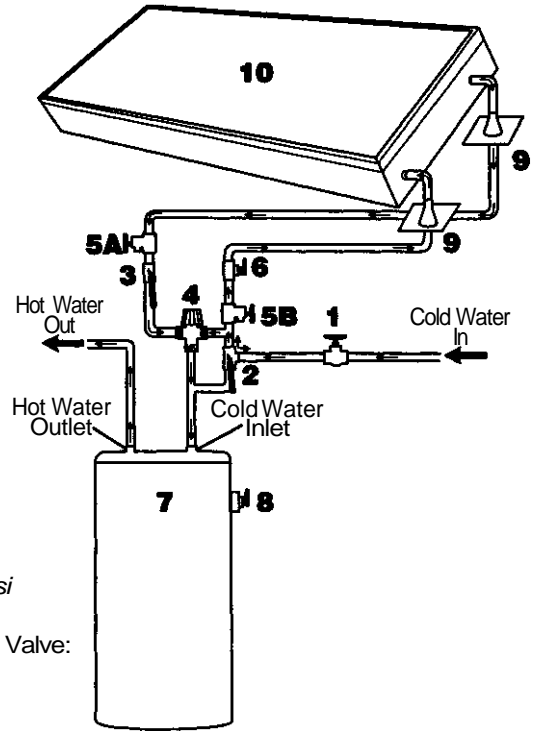

**2-WAY SYSTEM
FOR GAS WATER HEATERS**

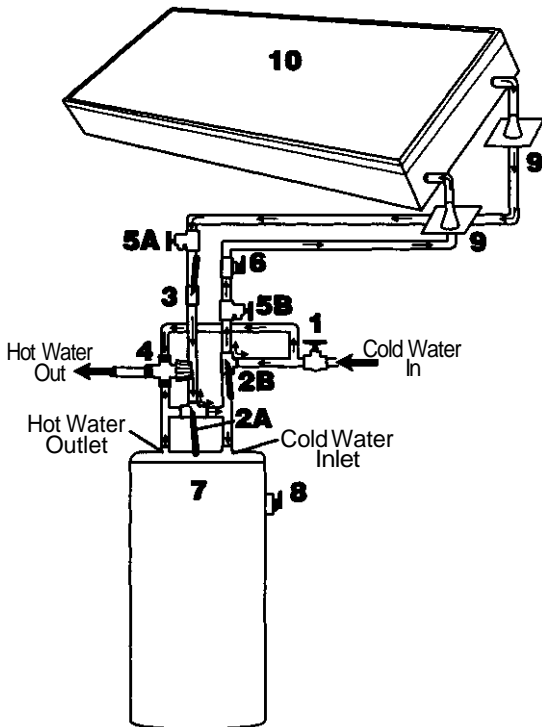

**SRCC OG 300
3-WAY SYSTEM**

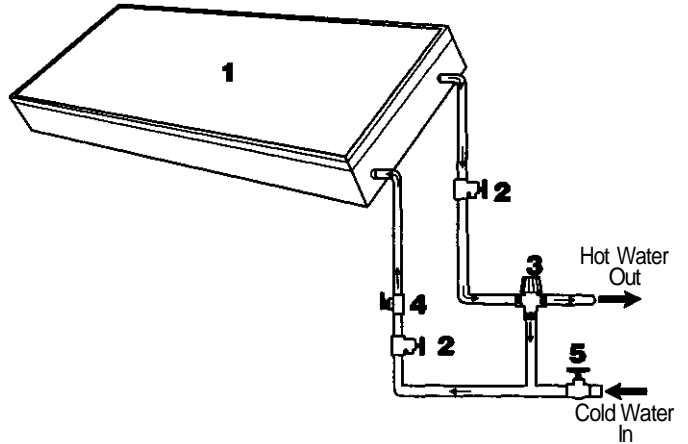

**DIRECT
SOLAR SYSTEM**

1. PROGRESSIVTUBE®
2. Boiler Drains: *Bronze*
3. Tempering Valve: *Set between 140°F and 160°F*
4. Pressure Relief Valve: *150 psi*
5. Supply shut off valve.

III. SYSTEM CHARACTERISTICS

All ProgressivTube Passive Solar Water Heaters are designed to efficiently collect solar radiation and to convert it into usable heat energy for household hot water usage. Do not use ProgressivTube units for heating or storing anything except POTABLE water.

The ProgressivTube system is a passive system because it has no moving parts and operates on local water pressure and solar radiation. There are no pumps or controls to maintain and no electrical energy is required to make it function. Once the system has been filled, it will operate at the flow rates that are normal to the household.

The collector/storage tank of the unit absorbs solar radiation through its highly selective surface which raises the temperature of the water stored in the collector. Water flows through the cold water supply line into the lowest tube of the unit. The tubes in the ProgressivTube are connected in series so that the top of the lower tube feeds the bottom of the next tube. This flow configuration ensures the delivery of the hottest water for each usage.

The colder replacement water is contained in the lower tubes where it is heated by the sun. When hot water is used in the household, solar preheated water is drawn into the conventional water heater, reducing or eliminating electricity or gas usage for heating water. (A direct solar system does not use a conventional water heater, hot water flows directly from the unit into the household).

IV. PRE-INSTALLATION CHECK LIST

1. Check local codes for plumbing and roof load requirements. Installations must meet all local code requirements for penetrating structural members and fire rated assemblies.
2. Obtain all applicable permits.
3. Inspect the roof. If it is in poor condition, advise the homeowner before the installation is begun.
4. Properly plan the installation by inspecting the attic and location of the conventional water heater. Discuss the proposed location of the system's major components with the homeowner to avoid any possible conflicts.
5. Make sure you have all necessary materials at the job site before starting the installation. Proper planning reduces labor and material costs.
6. ProgressivTube Solar Water Heaters are design for POTABLE WATER use only. The collector/storage tank is constructed of copper alloy #C-110. Each shipment of material shipped to TCT is certified to be greater than 99.05% pure copper. This alloy is the ANSI and ASTM standard for potable water piping. TCT's warranty on corrosion specifically states the "water must meet EPA Standards of Potable Drinking Water and have a PH maintained between 7.0 and 9.0 at all times". Some areas may not have water quality that meets this

warranty criteria. If water is too acidic, "pitting corrosion" can occur. If the situation is prolonged, the corrosion action can result in "pin-hole" leaks in the tubes. Pitting corrosion is always a clear indication of aggressive water. If there is a concern for water quality and the ability to maintain proper PH levels then measures should be taken to properly condition the water before it enters the household. Water softener/conditioners work very well to relieve this problem. If the situation cannot be resolved then considerations should be taken as to whether the installation should proceed.

V. INSTALLATION PRECAUTIONS

The following are important measures to follow to ensure a safe, trouble-free installation.

1. Remove the temporary labels after installing the unit (i.e., "IN", "OUT", and "DO NOT USE PIPE CONNECTIONS FOR HANDLES").
2. Remove the red plastic pipe caps before exposing the unit to full sunlight, otherwise they may melt onto the inlet and outlet nipples.
3. Be careful of the inlet and outlet nipples during installation. The unit can dry stagnate up to 400°F causing the nipples to produce severe burns if touched.
4. Do not lift or handle the unit by the copper inlet and outlet nipples, you could crack a weld and cause the unit to leak. This

is not covered by the warranty. Each unit is pressure tested to 165 psig during manufacturing and again at 50 psig before shipment.

5. Use 95/5 or 60/40 lead free solder for the collector piping because of the high temperature stagnation of the unit.

6. Keep the collector covered during installation. Even early morning sun can quickly heat up the absorber. It is most important that the unit be vented to the atmosphere before and while being filled. It is recommended that the collector be filled before soldering the return piping to the collector outlet, or open the pressure relief valve or open the boiler drain on the return line, or in some other fashion make sure the unit is vented to the atmosphere. Failure to follow these instructions will void the warranty and could damage the unit.

7. The collector should stagnate wet (filled) during times of non-use, except during severe winter conditions where temperatures are below 10°F. Under these conditions the collector and the solar loop piping should be drained.
8. Remember, the collector can easily produce 180°F to 200°F water during clear, sunny weather.

VI. COLLECTOR ORIENTATION

The installation site of the collector should be chosen so the unit receives maximum solar exposure.

It should never receive more than 10% shade on the collector absorption surface between 10:00 a.m. and 3:00 p.m. The location should be as close as possible to the conventional water heater to minimize the piping run, which should not exceed 100 feet.

For optimum performance in the northern hemisphere, the collector should face due south. Slightly decreased but good performance can be expected from a collector facing within 45° of due south. In the southern hemisphere the opposite direction, due north, is faced for optimum performance.

The unit tilted to local latitude in sunbelt areas will produce the best overall performance. (This rule of thumb should also be followed for installations in tropical zones such as the Caribbean). Increasing the tilt 10° to 15° in the sunbelt will improve winter performance and decreasing the tilt 10° to 15° will improve summer performance. In areas above the sunbelt, the tilt for best year round performance is latitude plus 10° to 15°. These parameters are valid in both northern and southern hemispheres.

VII. COLLECTOR MOUNTING HARDWARE OPTIONS

There are three mounting hardware options. The J-Bracket is used for installations on tile roofs. Any of the three mounting hardware options can be used with the J-Brackets.

Adjustable Tilt Mount ([Drawing A](#))
Fixed Mount ([Drawing B](#))
Flush Mount ([Drawing C](#))
J-Bracket ([Drawing D](#))

Choose the hardware system best suited for the particular installation.

The chart on page 8, "Mount

Dimensions and Angles" gives the tilt angle of the collector for the various Standoff lengths that are used with the Tilt Mount hardware. The chart also gives the width distance between roof penetrations for the Fixed and Flush Mount sets.

VIII. ROOF MOUNTS

The structure of the roof should first be examined to determine the dimensions of its members. Check applicable codes as to loading requirements. The roof penetrations should be located over an attic or similar space that is not blocked by a chimney, beams, or other obstacles.

Preparation of the roof area and procedures for anchoring to the roof members must be done carefully to avoid causing leaks or weakening the roof. In a new home installation, much of the mounting work can be performed after the roof has been framed and sheathed. In some cases, such as built-up roofs, the mounting work can be performed before the waterproof membrane is applied. On tile roofs, the mounting work is best performed after the waterproof membrane is applied but before the tiles are laid.

The ProgressivTube was specifically designed for maximum performance and draining when mounted horizontally. A level horizontal position is the only acceptable mount for installations above latitude 40°. Installing a unit in a vertical position is not recommended. If a unit is installed vertically there will be considerable air entrapment within the absorber/storage tank and, once filled, it is very difficult to drain.

A collector is exposed not only to sunlight and its destructive ultraviolet radiation but also to wind

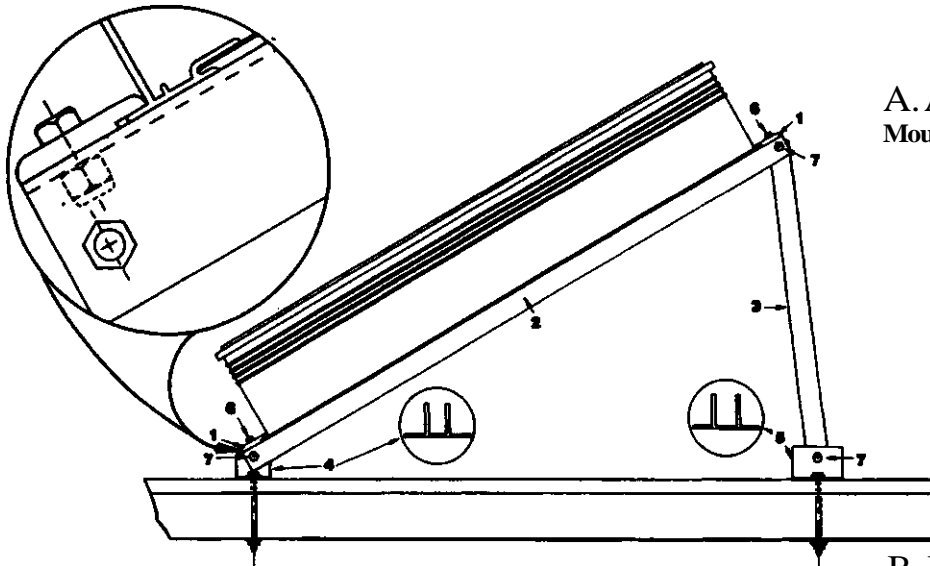

A. Adjustable Tilt

Mounting Hardware Parts:

1. Surface Clamps (4)
2. Cross Channel (2)
3. Standoff, 144" square tube, 1/8" wall (2)
4. Front Mount Base, 1" Double T (2)
5. Rear Mount Base, 1-1/4" Double T (2)
6. 1" x 3/8" Stainless Steel Bolts and Locknuts (4)
7. 2-1/4" x 3/8" Stainless Steel Bolts and Locknuts (6)

MOUNTING HARDWARE SYSTEMS

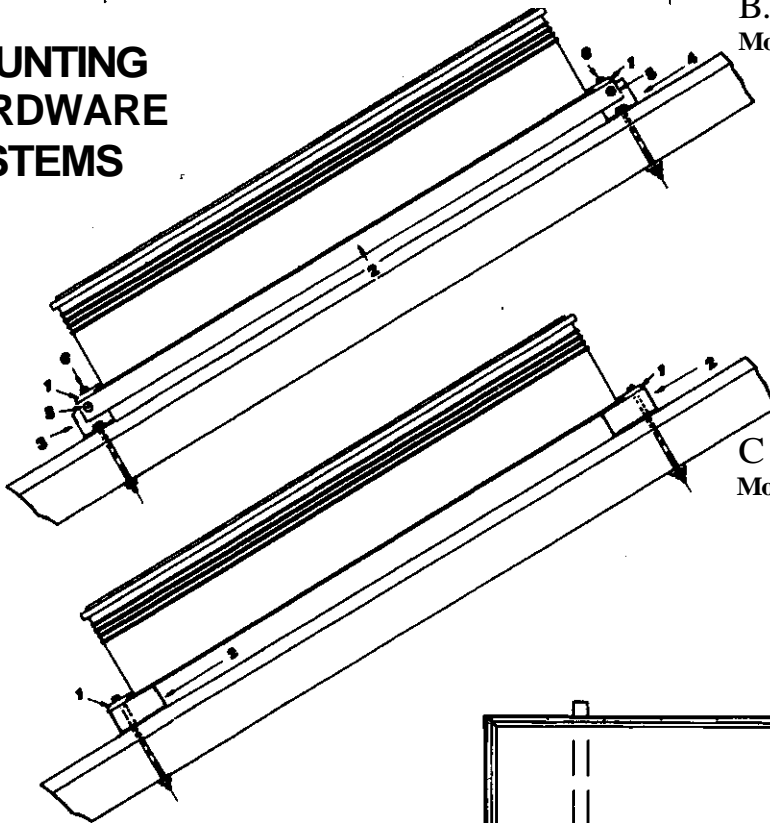

B. Fixed Mount

Mounting Hardware Parts:

1. Surface Clamps (4)
2. Cross Channel (2)
3. Front Mount Base, 1" Double T (2)
4. Rear Mount Base, 1" Double T (2)
5. 2-1/4" x 3/8" Stainless Steel Bolts and Locknuts (4)
6. 1" x 3/8" Stainless Steel Bolts and Locknuts (4)

C Flush Mount

Mounting Hardware Parts:

1. Surface Clamps (4)
2. Treated 2" x 6" wood blocks under surface clamps supplied by contractor

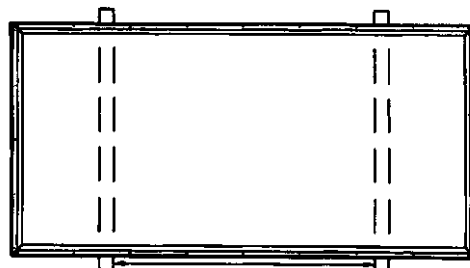

MIN. 42" BETWEEN CROSS CHANNELS

D. J-Bracket Roof Mount

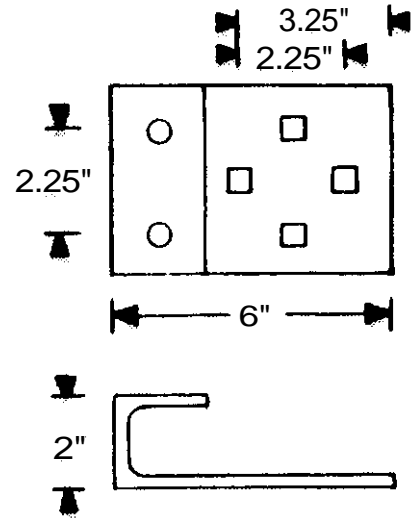
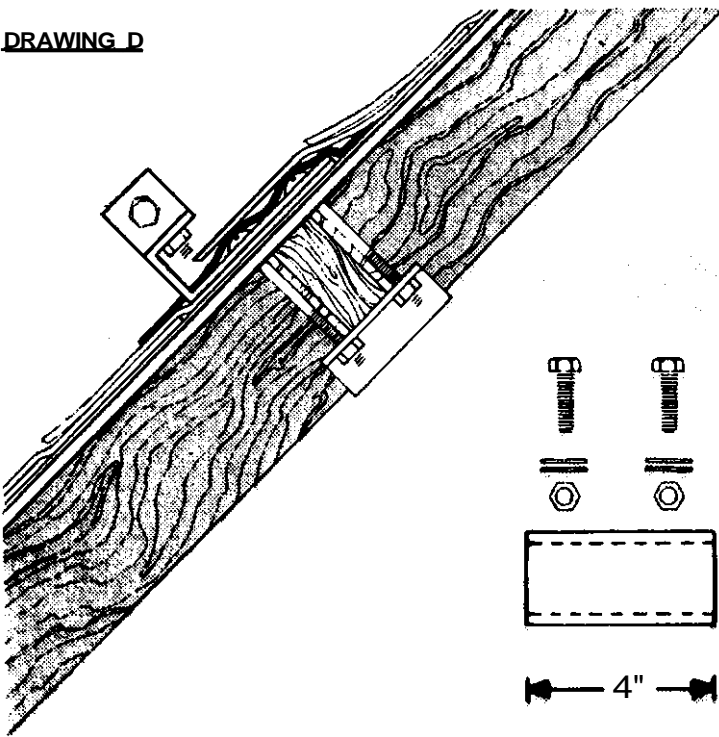

MOUNT DIMENSIONS AND ANGLES

Tilt Mount

Collector	Standoff	Dim. "A"	Angle
PT-30/35-CN	1 Foot	35 ⁵ / ₁₆ "	17°
PT-30/35-CN	2 Foot	29 ¹ / ₈ "	38°
PT-30/35-CN	3 Foot	12 ⁵ / ₈ "	70°
PT-40/50-CN	1 Foot	47 ³ / ₄ "	13°
PT-40/50-CN	2 Foot	43 ⁵ / ₁₆ "	28°
PT-40/50-CN	3 Foot	34 ¹ / ₂ "	45°
PT-40/50-CN	4 Foot	14 ⁵ / ₈ "	72°

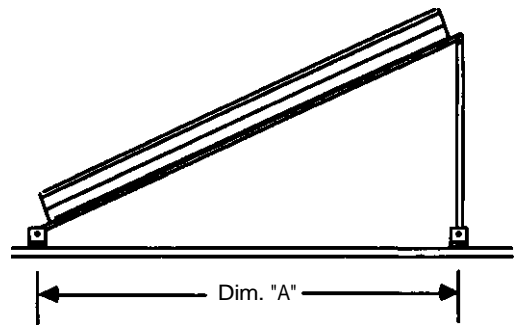

Flush & Fixed Mount

Collector	Dim "B"
PT-30/35-CN	36 ⁷ / ₈ "
PT 40/50-CN	48 ⁷ / ₈ "

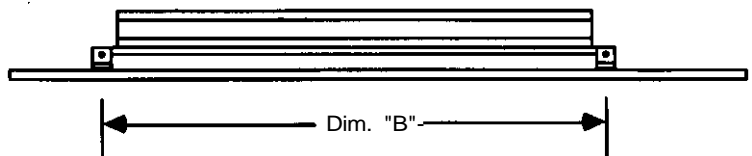

DRAWING E
Pipe Flashing Cross Section

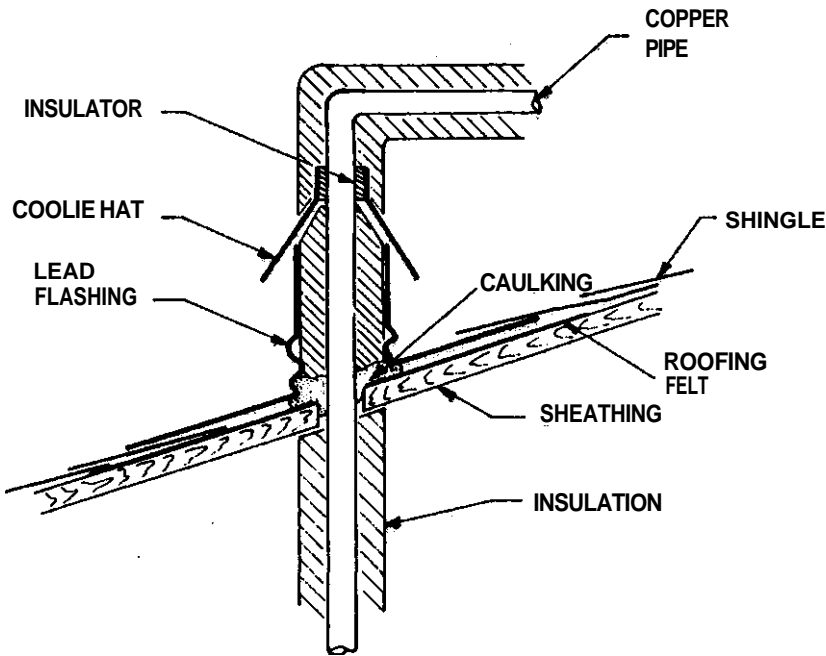

DRAWING F.1
Types of sealed-roof penetrations

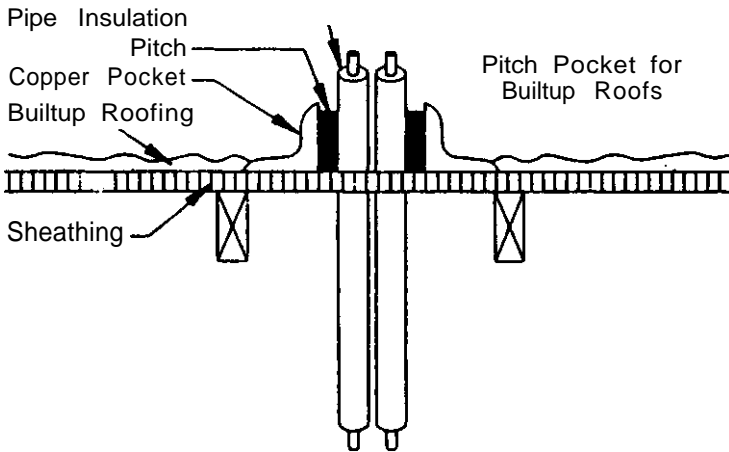

DRAWING F.2

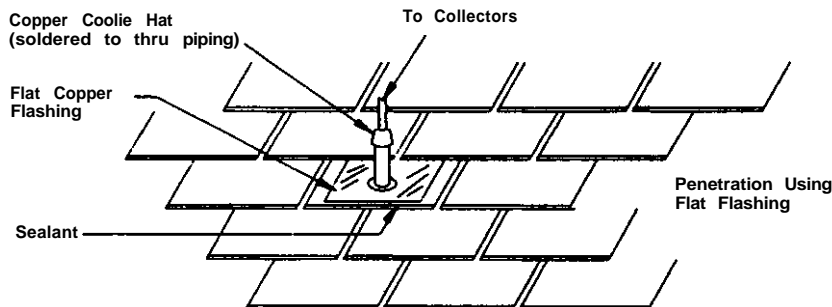

forces. Collectors installed in areas that experience hurricane force winds are particularly challenged. Florida codes require that a collector and its mounting structure be able to withstand intermittent windloads up to 130 mph. ProgressivTube units and mounting hardware have been windload tested to 180 mph and hundreds of units have survived storms with winds in excess of 200 mph. The structural integrity of a collector is most important when considering long-term performance.

Load Bearing and Bracing

Whenever possible, mount the collector over a load-bearing wall or near the peak of the pitched roof (usually within 15" of the roof crown). If neither of these sites are practical and the collector must be installed on an open span of roof, extra means must be employed to ensure a safe, proper installation. If the roof structure is of 2" x 4" truss design, spread the load over at least five trusses and reinforce or brace all truss members where needed or to comply with local building codes. **See the Typical Roof Bracing drawings in the Appendix** for suggested roof structure bracing.

NOTE: When filled, a single ProgressivTube collector can weigh between 240 lbs. and 665 lbs. DO NOT mount the collector without adequate support as determined by applicable building codes and sound building safety practices.

Roof Piping and Penetrations

It is best to locate pipe penetrations through the roof as close to the collectors as possible (**see Detail J in the Appendix**). In some cases it may be possible to pipe both the supply and the return lines through the same penetration

(see Drawing F.1). Piping through the roof must be weatherproofed. Usually, a hole is drilled in the roof large enough for the copper pipe to pass through. A standard plumbing roof vent stack flashing cover is placed around the hole with its base cemented to the roof using appropriate roof caulking such as polyurethane and its upper edge slid under the adjoining shingle. Caulking is then placed in the top and around the copper pipe and insulation. A "coolie cap" can be fashioned, **(see Drawing E)**, to provide a waterproof seal. Another method is to make a flat copper flashing with an oversize tube, which is penetrated by the copper water pipe. A coolie cap is made from a reducing coupling that fits the oversized copper tube and is large enough for the copper water pipe to just pass through. It is then soldered to the oversized copper tube and the copper water pipe. **(See Drawing F.2).** Make sure the pipe penetrations are downhill from the collector connections. Water will not drain uphill.

DRAWING F.3

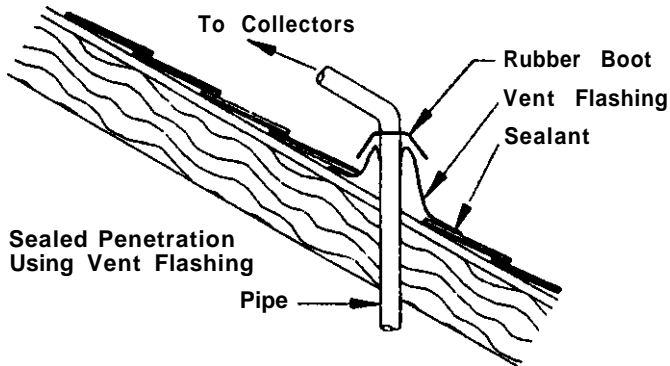

DRAWING G.1

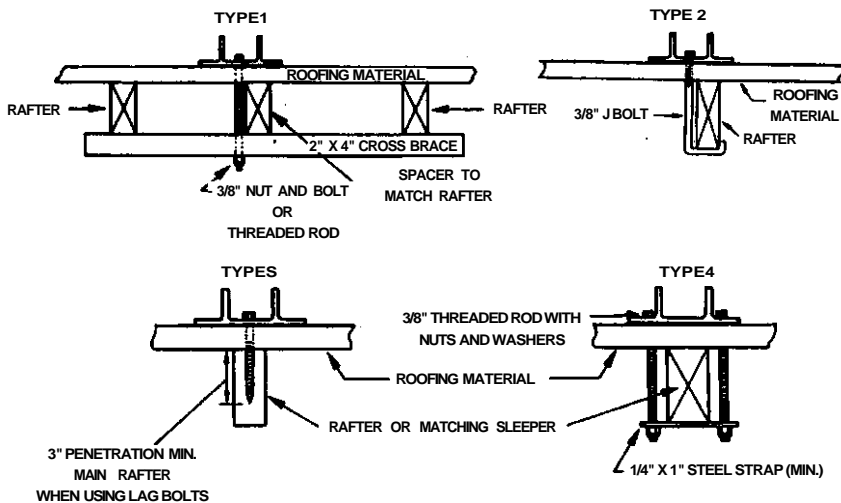

PITCHPAN OR OTHER WATERPROOFING METHODS NOT ILLUSTRATED

Roof Mount Penetrations

Roof penetrations for mounting the collector can be any of the methods shown in **Drawing G.1**. Appropriate waterproofing methods must be used. Pitch pans, mounting blocks, or flashing under the mounting bases and roofing material, sealed with caulk are recommended. Consult the Waterproofing and Roof Attachment drawings (**Details A through E**) in the Appendix for additional details.

In retrofit situations, rafters or roof trusses may be located from inside the attic if the crawl space is large enough to permit access. Small galvanized nails may be driven up beside the rafters at the desired anchoring points; this locates the

DRAWING G.2

A method of locating mounting points

4. Pop a chalk line down roof along truss.

3. Measure to approximate truss position along roof ridge.

5. Measure to actual mounting points and prepare roof surface.

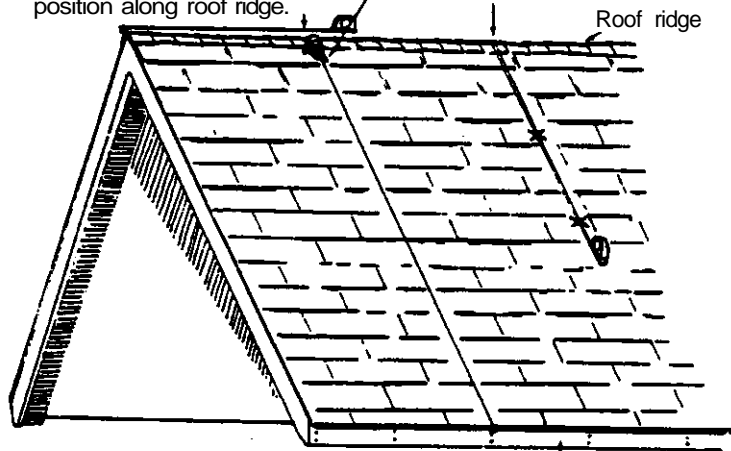

1. Locate nails in fascia either visually or with stud finder (trusses are usually mounted on 2-foot centers).

2. Choose mounting trusses.

DRAWING G.3
Reverse Pitch

Standoffs should be anchored on the roof with the degree at angle "A" being less than 75 degrees.

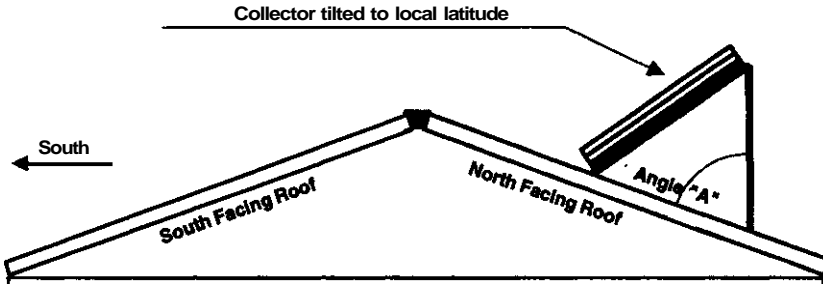

utilized for the collector location unless there are shade or aesthetic problems. Follow the guidelines in Section VI Collector Orientation, while taking into consideration the appearance of the system on the home. Homeowners prefer systems that are not obtrusive and blend in with the general architectural lines of the home.

penetration points for the installers on the roof. Measure and mark the four roof penetration points for the mounting bolts.

If access to the attic is not adequate, trusses can be located by looking for nails in the fascia board. They show the location and spacing of the trusses. Locate the mounting points by measuring across the roof ridge and popping a chalk line between the ridge and the fascia along the run of the truss (see Drawing G.2). The truss may not be perfectly straight, so the chalk line will be close to, but not precisely on, the truss run. Many installers use the variation in tone associated with external hammer blows to locate the run of the truss.

Most roofs are either asphalt or fiberglass shingles. They are stapled or nailed in an overlapping pattern over the felted plywood that comprises the roof sheathing. Old, brittle asphalt shingles may break underfoot. Use care until the condition of the shingles is ascertained. Mount bases can be installed directly over pliable shingles; no special preparation is necessary. Holes for the anchoring bolts should be drilled through the shingles. The penetration holes should be completely encircled with roof sealant to provide for a

watertight seal.

Roofs with hard, non-flexible shingles such as cedar shake and asbestos should be treated the same as tile roofs.

Standing seam metal roofs are treated much the same as flexible shingle roofs. The mount bases can be installed directly over the metal sheathing. On corrugated metal roofs the penetrations must be made on the crown of the corrugation, never in the valley. Special care must be taken when sealing this type of roof.

South/North Roof Mounts

Most homes have a south facing roof. This roof area should be

Either the Fixed Mount or Flush Mount hardware systems are used for this situation. The collector is installed parallel to the plane of the roof and the edge of the collector should be in parallel with the roof ridge line. The Fixed Mount system raises the collector approximately 2.5 inches above the roof to allow air to circulate under the collector and to prevent debris from accumulating along the top of the collector. If using the Flush Mount system, 2" x 6" pressure treated lumber blocks are used to create the air space under the collector (see Drawing C). To avoid potential roof damage from mildew and rotting it is not recommended for the collector to sit directly on the roof surface unless a watertight seal is made between the collector and roof surface. The watertight sealing technique described in the "Tile Roof Installations" section may not be sufficient enough to

DRAWING H

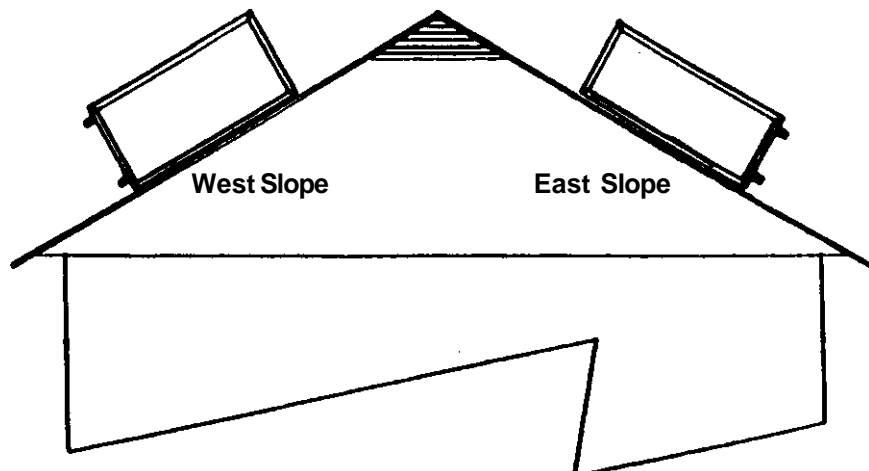

provide a long term seal on shingle or metal roofs because the exterior portion of the sealing material will be exposed to direct solar radiation which could shorten its design life.

Sometimes the collector cannot be installed on the south facing roof. An alternative is to use a **Reverse Pitch installation (see Drawing G.3)**. The adjustable tilt mount hardware system is used with extra long standoffs. Usually, three foot standoffs are adequate for PT-30-CN or PT-35-CN units and four foot standoffs for PT-40-CN and PT-50-CN units.

East/West Roof Mounts

Homes that do not have an acceptable south facing or reverse pitch location or that have only a north/south roof ridge line must use the Adjustable Tilt Mount system. The mounts are anchored to parallel rafters and the collector is installed perpendicular to the roof plane, facing south, at an angle equal to local latitude. This installation is sometimes referred to as a "sawtooth position".

For east or west facing roofs, the piping connections should always face downwards (**see Drawing H**). When installed on a west roof, the inlet pipe will become the outlet pipe and visa versa. The west roof installation will result in slightly reduced performance, some air entrapment and will only partially drain; therefore, this installation should only be used if no other position is available. The west roof installation position should particularly be avoided in severe freezing climates. In moderately freezing climates a freeze prevention valve must be used on east and west roof installations. East roof installations will have no air entrapment or loss of performance. A collector on an east roof will drain most of the

water in the tank but the greater the slope of the roof the more water retained in the tank. The collector must not be mounted on an east or west sloping roof that has a pitch greater than 35°.

DO NOT MOUNT THE UNIT VERTICALLY.

Tile Roof Installations

ProgressivTube collectors are easily installed on tile roofs; either above the tile using J-Brackets or flush to the roof with the tile abutted to the collector. **Installation Details F and H in the Appendix** illustrate these two methods. For anchoring the collector to the roof, the Spanner Mount (**Detail A**) is recommended. This technique allows for greater placement flexibility.

Tile roofs require more preparation than shingle roofs. When walking on these roofs, care must be taken not to break the tiles or slip on loose ones. Never walk on the crowns of barrel tiles. Broken tiles must be repaired with roofing adhesive or replaced. This can increase installation time and cost. Tiles in the area of the intended mounting penetrations may be broken up with a hammer and removed or, for a cleaner and quicker installation, sawed out. Remove as few tiles as possible because the area must be totally sealed upon completion of the mount bracket installation to protect the underlying waterproof membrane. When the tiles are removed, the exposed waterproof membrane may be treated as if it were a shingle roof. The broken tile may be replaced with colored cement molded to look like the unbroken tile or a tile may be sized to cover the mounting hardware base and anchoring bolt.

On Top of Tile:

The following basic procedures

should be followed when installing the collector on top of an existing tile roof (**see Detail F in the Appendix**). These procedures apply to both flat and barrel tile.

1. Determine the exact location on the roof where the four collector mounting hardware roof penetrations are to be made.
2. Carefully remove one or two tiles at each location. If the tile are "mudded" to the weatherproof membrane, be sure not to tear or otherwise compromise the integrity of the membrane.
3. Clean off each location of all membrane grit, dirt, and tile debris.
4. Drill the four penetration holes into the roof. If using lag bolts, be sure the starter holes are in the center of the rafter. Because of the added difficulty of installing on tile roofs it is sometimes much easier to use a spanner mount across the rafters. See **Detail A** for proper spanner installation.
5. Seal the roof penetration holes by liberally encircling the holes with polyurethane or butyl rubber caulking compound.
6. Spread a thick coating of caulking compound on the bottom of the J-Bracket so it will be completely covered when set in place and bolted to the roof. Caulking compound should seep out all along the bottom edge of the J-Bracket as the anchoring bolt is tightened into place.
7. After the J-Bracket is securely fastened to the roof, cover the head of the anchoring bolt and the entire back portion of the J-Bracket with caulking compound.
8. Replace as much tile as possible over the J-Bracket base as shown in **Detail F**. A saw may be needed to cut the tile the proper length. After sizing the tile, slide the back of it under the first tile

above the J-Bracket. Be sure to apply generous amounts of caulking compound between the sized tile, the roof and the J-Bracket. The sized tile should overlap the anchoring bolt and as much of the J-Bracket as possible.

9. Once all four J-Brackets are secured, caulked and re-tiled, they are ready for the mount bases to be bolted on. Proceed with the remainder of the hardware installation.

Flush To The Roof:

ProgressivTube collectors can be installed flush to the weatherproof membrane of a tile roof if a watertight seal can be formed between the bottom of the collector and the membrane (*see Details H and I*).

The following basic procedures should be followed when installing the collector flush to the roof. These procedures apply to both flat and barrel tile.

1. Place the collector on the membrane in the exact location it will be anchored.
2. With a carpenter's pencil or other suitable marker, trace the outline of the collector onto the membrane. Do not use a sharp instrument which might cut into the membrane.
3. Move the collector aside.
4. Place Jiffy Seal 500, 6" wide sealing compound over the collector outline. Start at the top of the collector outline and lay the strips as shown in *Detail I*.
5. Be sure the strips overlap the collector outline by at least 1 3/4".
6. Remove the clear plastic protective lining on the Jiffy Seal. Lay the exposed side of the sealing compound on the membrane and press into the roof with palms of hands.

7. After all four strips have been laid into place, use a rubber mallet and firmly hammer the entire strip down.

8. Remove the white paper protective lining of the Jiffy Seal.

9. Carefully place the collector on the sealing strips. Once in the desired location, press the collector into the sealing compound.

10. Anchor the collector with the Flush Mount hardware. The Flush Mount clamp should have the overlap of the sealing compound completely beneath it so that a 1/2" or more of compound is exposed at the end of the clamp.

11. Once the collector is anchored, complete the piping connections.

12. Carefully notch-out the seal compound for the pipes if necessary. A flat, even surface is necessary to properly seal the piping and pipe roof jacks.

13. Use a mallet and firmly hammer the sealing compound overlap all around the collector to ensure a tight seal. Fill any gaps in the seal with caulk.

14. The tile can now be set flush to the collector. Caulking can be used to fill any gaps between the collector and the tiles.

IX. GROUND MOUNTS

Ground mounted systems are the fastest and simplest installations. A ground mount must have a stable, permanent foundation. A concrete HVAC pad or four standard concrete piers embedded at least halfway in the ground, are the recommended foundations (*see Drawing I*). **Be sure to coat the threaded end of the bolts** that secure the collector base mounts with silicone caulk to prevent rust.

The lower edge of the collector should be at least one foot above

the ground so it will not be obstructed by vegetation or partially submerged in standing water. Collectors mounted at ground level can be more susceptible to damage (flying rocks from lawnmowers, etc.) or vandalism. The placing of an expanded metal mesh screen in front of the glass may be helpful in preventing breakage.

In ground mount systems, if the collector is lower than the auxiliary tank within the house, then the solar loop piping must slope downward from the house to the collector (or piping can be buried in the ground running horizontally).

A boiler drain must be installed in all ground mounts at the collector inlet. A boiler drain or a vacuum breaker must be installed at the collector outlet. Buried piping must be properly insulated (min. 3/4" wall) and non-degradable. In areas where severe freezing occurs, all underground piping must be below the frost line and insulated with a minimum 1-1/2" wall insulation (*see Drawing J*). For ground mount systems that have two or more collectors, a boiler drain must be installed at the inlet connection of all units and a vacuum breaker or boiler drain must be installed at the outlet of each unit.

X. SYSTEM PLUMBING

A ProgressivTube unit can be installed as a pre-heater system or as a direct solar system. Consult the recommended System Plumbing Diagrams for the type of system to be installed.

All piping must meet local code requirements for potable hot water service and must be installed to slope 1/4" per foot of pipe run to insure proper drainage under shut down conditions. Typically, piping must be 1/2" or 3/4" diameter type "L" or "M" copper tubing sweated

RECOMMENDED FOUNDATION FOR GROUND MOUNT INSTALLATION

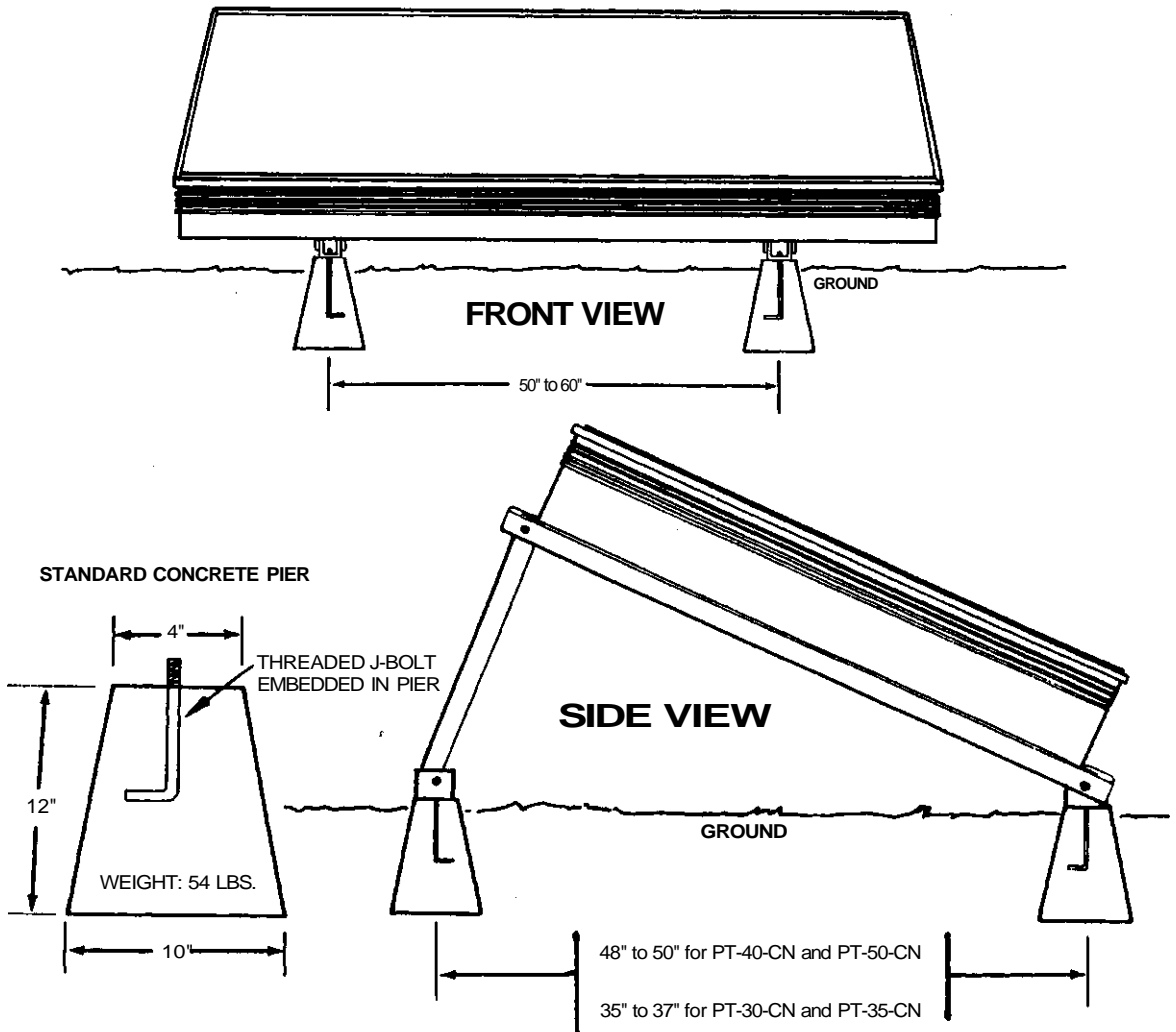

with 95/5 or 60/40 lead free solder. Soft copper tubing is recommended because of its ability to expand during mild freezing conditions. **Never use PVC or CPVC piping for the solar loop.** The total length piping from the collector to the storage tank should not exceed 100 feet; the longer the pipe run, the greater the heat loss. If a greater length is necessary, an increase in piping diameter may be required.

When plumbing Direct Systems

(particularly in low latitude areas of the world) in a building which has PVC plastic piping for the cold water supply, CPVC must be stubbed to the PVC before connecting to a 20' copper stub attached to the ProgressivTube inlet connection. Excessive heat can migrate through the inlet connection and down the copper stub. It is advised that the cold water supply piping in Direct Systems installed in low latitude areas not be insulated to allow this

migrating excessive heat to dissipate.

All systems should use bronze or brass valves rated at 400 psi W.O.G. and 100 psi at 300°F. There must be a shut-off valve on the cold water supply and boiler drains on the supply and return sides of the solar loop. It is recommended the boiler drain on the supply side be installed slightly lower than the boiler drain on the return pipe to facilitate draining.

DRAWING J

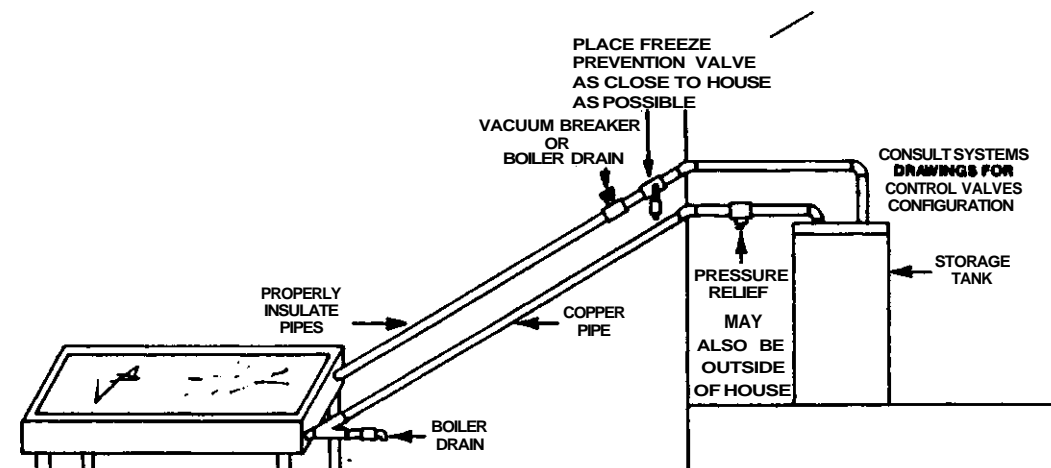
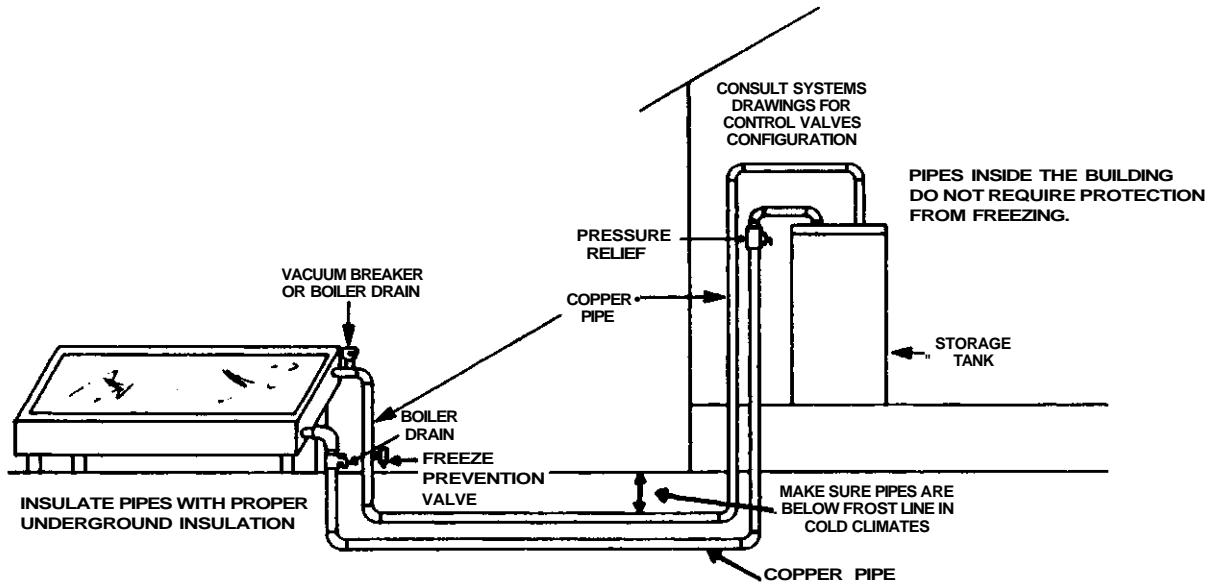
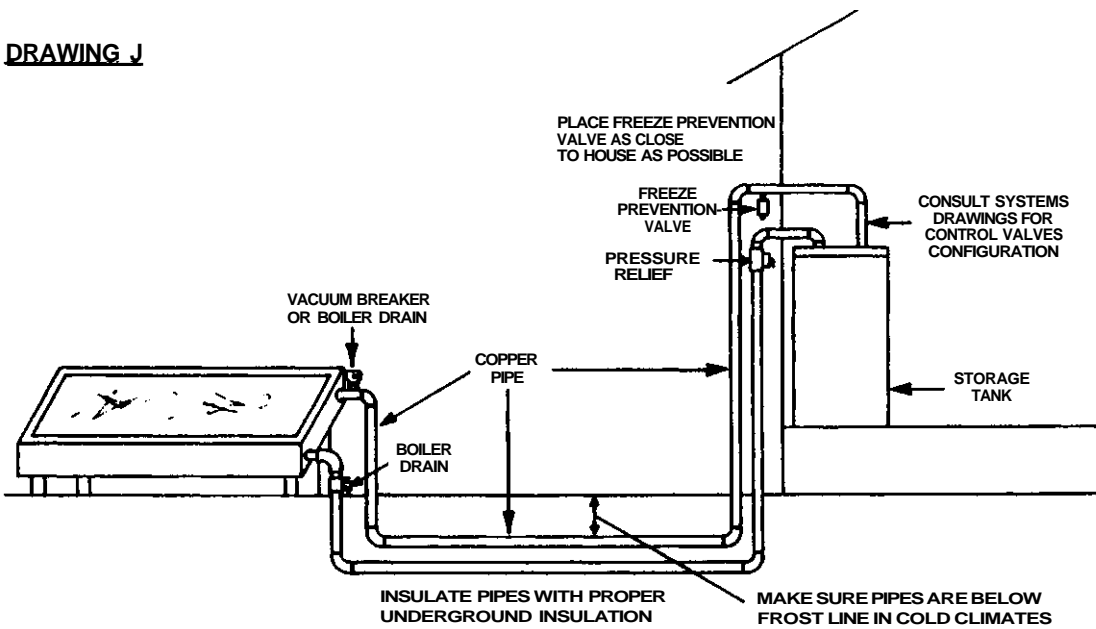

Pre-heater systems plumbed to a conventional gas water heater must have a tempering valve installed in the return line of the solar loop piping. Set the valve between 120°F and 145°F. Systems that pre-heat conventional electric water heaters can have a tempering valve installed (as an option) in the hot water supply piping to the house. Set the valve between 120°F and 145°F. The use of the Aquamix Anti-scald tempering valve is highly recommended for all installations. It is required for all SRCC OG 300 certified installations. When deciding the temperature setting of the valve, the contractor should consider who will be using the system. **The chart below** illustrates exposure times at various water temperatures that can result in serious injury. Direct solar systems must use a tempering valve to prevent scalding because a ProgressivTube can easily produce 180°F to 200°F of hot water during clear sunny weather. The valve should be installed where it is not exposed to

Third Degree Burn Chart

Temperature	Time Adults	Time (Young Children/ Adults over 65)
120	9.5min.	
125	2.0min.	
130	30secs.	10.0secs.
135	15secs.	4.0secs.
140	5secs.	1.0secs.
145	2.5secs.	
149		0.5secs.
150	1.8secs.	
158	1.0secs.	

the weather. Direct solar systems should not use plastic pipe to feed cold water to the tempering valve. The water from the collector can melt the pipe from the valve. High temperature CPVC plastic pipe may

be used down line of the tempering valve if a six foot copper stub is installed in the tempering valve before the plastic pipe.

The flow control valve for pre-heater systems (direct solar systems do not need a flow control valve) is used to by-pass the collector so that it may be drained for severe winter shut-down or in the unlikely event of a problem with the collector. The by-pass mode will allow the conventional water heater to continue to provide hot water for the house. The recommended flow control valve is a 3-way ball valve. For FSEC certified two-way systems the flow control valve is the 3-way ball valve identified as valve #2 in the plumbing schematics. In the SRCC schematic it is valve #2B.

The 3-way ball valve should be cast bronze with a stainless steel or chrome plated ball. Caution should be used when soldering a ball valve into place. Be sure to keep it cool with a wet cloth to protect the plastic ball seats from the heat.

All systems must have a 150 psi pressure relief valve installed in the solar loop piping between the collector and the flow control valve. The valve may be installed in the supply side of the solar loop piping, the return side of the solar loop piping, or at the collector on either the inlet or the outlet pipe connection. The supply side pipe is the recommended preferred location as is shown in both the FSEC and SRCC approved system schematics. Some local codes may require the pressure relief valve to have a drain line. If the valve is installed in the supply line as shown in the plumbing schematics, its drain line can follow the same route as the drain line from the T & P valve on the

conventional water heater. Some local codes will allow both valves to share the same drain line, some will not.

A check valve is used only if a freeze prevention valve is installed. It should be installed in the return solar loop piping below the boiler drain to prevent short circuiting of the freeze prevention valve during cold weather. Use a check valve that is designed for back-flow prevention when installed in a vertical position.

XL SYSTEM INSULATION

All piping, fittings, valves, and the conventional water heater must be well insulated. Even small sections of bare pipe will cause substantial heat loss at elevated temperatures. The cold water supply line will also conduct heat away from the system unless it is insulated. Only Direct Systems installed in tropical or low latitude areas should have un-insulated supply lines. Use a 3/4" wall, closed-cell tube insulation such as Rubatex, Armaflex, or Insul-tube in mild climates. In cold climates, where freezing occurs, 1.5" wall insulation must be used. The **chart on page 17** illustrates the freezing characteristics of various copper pipe and insulation configurations. Remember, TCT's warranty does not cover freeze damage to any system piping. All tube insulation exposed to sunlight must be protected from UV degradation. Use pipe insulation jackets or a coating of exterior grade latex paint, or metal tape. Do not use duct tape because it will quickly deteriorate when exposed to outdoor conditions. If the solar system is retrofitted to a pre-existing conventional water heater, the water heater should be insulated with an extra super insulation jacket. At least two inches of fiberglass matt is

PIPE FREEZE TIMES
RUBATEX and ARMAFLEX
K = 0.270 Btu-in/hr-F-sq ft

	TYPE M				TYPE L			
Pipe ID/OD (in.)	0.811/0.875				0.785/0.875			
Insulation (R)	2.6	4.4	6.3	10.7	2.6	4.4	6.3	10.7
Thickness (in.)	0.50	0.75	1.00	1.50	0.50	0.75	1.00	1.50
AMBIENT (F)	HOURS TO FREEZE SOLID				HOURS TO FREEZE SOLID			
30	89.0	116.7	139.0	173.9	83.6	109.5	130.4	163.1
29	59.7	78.3	93.2	116.6	56.1	73.5	87.5	109.5
28	45.0	59.0	70.3	87.9	42.3	55.4	66.0	82.5
27	36.1	47.3	56.4	70.6	33.9	44.5	53.0	66.3
26	30.2	39.6	47.1	59.0	28.4	37.2	44.3	55.4
25	26.0	34.0	40.5	50.7	24.4	31.9	38.1	47.6
24	22.8	29.8	35.5	44.4	21.4	28.0	33.4	41.7
23	20.3	26.5	31.6	39.6	19.0	24.9	29.7	37.2
22	18.3	23.9	28.5	35.7	17.2	22.5	26.8	33.5
21	16.6	21.8	26.0	32.5	15.6	20.5	24.4	30.5
20	15.3	20.0	23.8	29.8	14.3	18.8	22.4	28.0
19	14.1	18.5	22.0	27.5	13.3	17.4	20.7	25.9
18	13.1	17.2	20.5	25.6	12.3	16.1	19.2	24.1
17	12.2	16.0	19.1	23.9	11.5	15.1	18.0	22.5
16	11.5	15.1	17.9	22.4	10.8	14.1	16.9	21.1
15	10.8	14.2	16.9	21.1	10.2	13.3	15.9	19.9
14	10.2	13.4	16.0	20.0	9.6	12.6	15.0	18.8
13	9.7	12.7	15.1	18.9	9.1	11.9	14.2	17.8
12	9.2	12.1	14.4	18.0	8.7	11.3	13.5	16.9
11	8.8	11.5	13.7	17.1	8.3	10.8	12.9	16.1
10	8.4	11.0	13.1	16.4	7.9	10.3	12.3	15.4
9	8.0	10.5	12.5	15.7	7.5	9.9	11.8	14.7
8	7.7	10.1	12.0	15.0	7.2	9.5	11.3	14.1
7	7.4	9.7	11.5	14.4	6.9	9.1	10.8	13.6
6	7.1	9.3	11.1	13.9	6.7	8.8	10.4	13.0
5	6.8	9.0	10.7	13.4	6.4	8.4	10.0	12.6

"Hours to Freeze Solid" are calculated figures. Actual freezing times may be shorter due to prevailing weather conditions.

DRAWING K

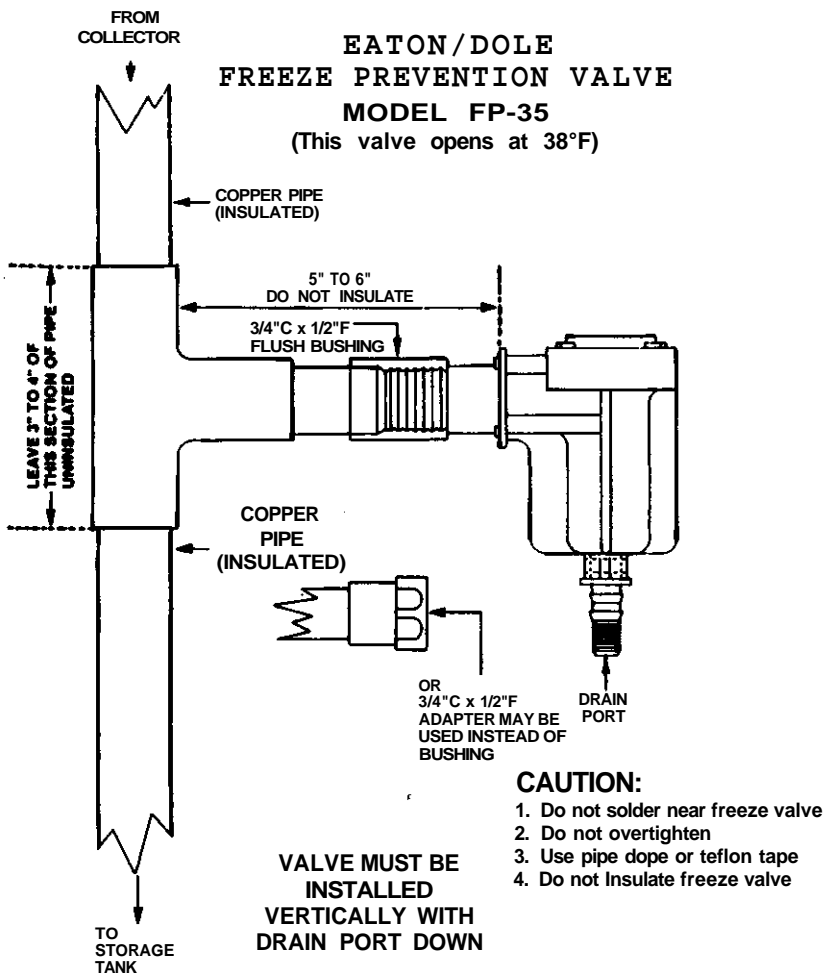

Diagrams. A recommended option for all systems installed in areas that experience freezing conditions is an automatic freeze prevention valve such as the Eaton/Dole FP-35. The valve should be installed according to the manufacturer's recommendations (and Drawing K) on the return solar loop piping between the collector and the roof (consult the System Plumbing Diagrams). A swing type check valve must also be installed on the return solar loop piping to prevent short circuiting of the freeze prevention valve. Thermostatically controlled pipe heat tape can also be used as a freeze prevention measure for the piping.

Because contractors have greater knowledge and experience of their local winter weather patterns and conditions, it is their responsibility to decide if a freeze prevention valve or heat tape is necessary for the system.

In northern climates, the collector should be shut down by draining during any months that average or exceed 1,000 heating degree days. The collector should also be drained whenever severe freezing conditions exist, below 10°F with overcast skies. Good performance can be expected from ProgressivTube systems during daytime conditions of clear skies and cold ambient temperatures. It is most important for local contractors to realize it is their responsibility to use the most appropriate and reliable techniques necessary for their area to prevent freeze damage to their customer's piping or collector.

XIII. TWO OR MORE COLLECTOR SYSTEMS

Households with more than six members or with a large hot water

recommended (see Detail G In the Appendix). If the conventional water heater is of the high efficiency type insulated with R-12 or better foam insulation, it will not need additional insulation.

XII. FREEZE PREVENTION

ProgressivTube collectors are virtually freeze proof throughout the Sunbelt area of the country due to their thermal mass and heavy insulation. However, the pipes leading to and from the collector can freeze. Collector piping should be as short as possible and should penetrate the building as close to the conventional water heater as

possible to minimize exposed runs of piping. Exposed piping or piping in unheated attic spaces must be insulated with a minimum of 1 1/2" wall insulation. It is extremely important that all piping be installed to slope a minimum of 1/4" per foot of pipe run to ensure proper draining during severe cold weather. The following table is a guide to the hours required to freeze solid 3/4" type M and type L copper pipe that has been wrapped with Armaflex/Rubatex pipe insulation of various thickness.

All systems must have a manual drain down capacity as discussed in the System Plumbing section and shown in the System Plumbing

DRAWING L

Two Unit System Piped in Parallel

Recommended Configuration

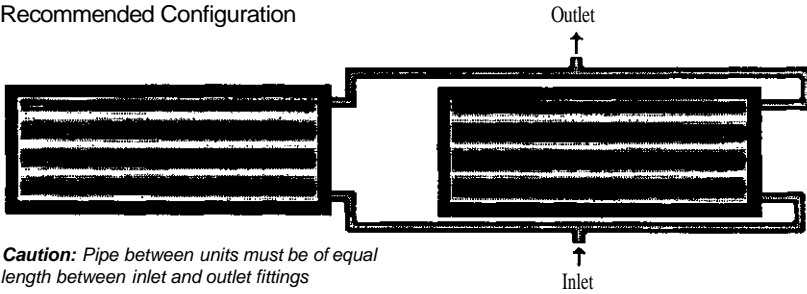

Caution: Pipe between units must be of equal length between inlet and outlet fittings

Alternative Configuration

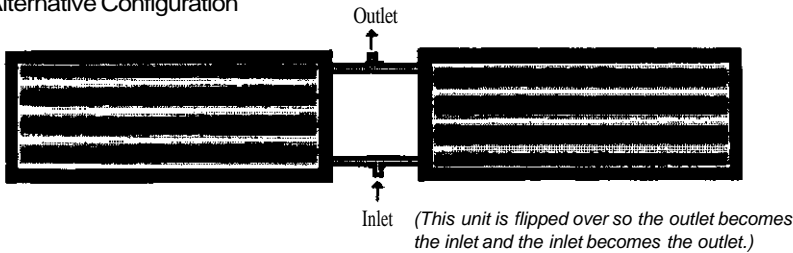

demand, should consider having a two unit system. Light commercial applications such as restaurants, car washes, housing with central hot water systems, swimming pool bath houses, and process hot water can be served with multiple collector systems.

Two unit systems must be plumbed together in parallel to ensure that both collectors drain properly. The piping flow paths must be of equal length so each collector receives equal flow pressure. Make sure all piping slopes 1/4" per foot so the collectors and all piping drain completely.

A two unit system could be plumbed in series, but only in non-freezing areas because the second collector cannot be easily drained. If a series configuration is necessary, a boiler drain must be installed at the inlet and the outlet of the second collector or else the supply line and the return line have to be disconnected from the collector in order for it to drain. The performance of two unit systems is equal whether plumbed in parallel

or series so the ability to drain and the ease of performing this function are the main considerations when choosing the flow pattern.

As shown in **Drawing L**, the Recommended Configuration has both units installed in the normal horizontal position with the inlet/outlet pipe nipples on the right hand side of the collector. This configuration has a considerable length of piping exposed on the roof. Be sure to insulate this piping

DRAWING M

Proper positioning of two units on south roofs

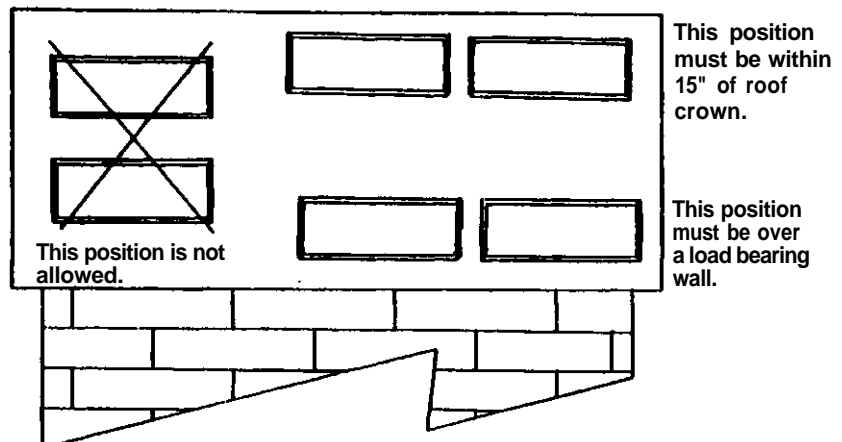

well and to run it as close to the collectors as possible to limit any possible negative aesthetics. If the collectors are tilted up, the piping can run behind them, making a much cleaner looking installation.

The Alternative Configuration has improved aesthetics by "flipping" the second collector around so the pipe nipples are on the left hand side of the collector facing the pipe nipples of the first collector which is installed in the normal horizontal position. The inlet on the second collector now becomes the outlet and the outlet becomes the inlet. This configuration is acceptable but there are three factors that could effect performance. In-house testing has shown that a flipped collector will have slightly reduced performance, some air entrapment, and will only partially drain. The contractor will have to decide the requirements of each installation when choosing which configuration to use.

Proper positioning of a two unit system is an important consideration because of potential excessive roof loading. On south facing roofs the units must be installed side by side, as in **Drawing M**. Never install two units one above the other on the same rafters. Be sure

DRAWING N

Proper positioning of two units on east/west roofs

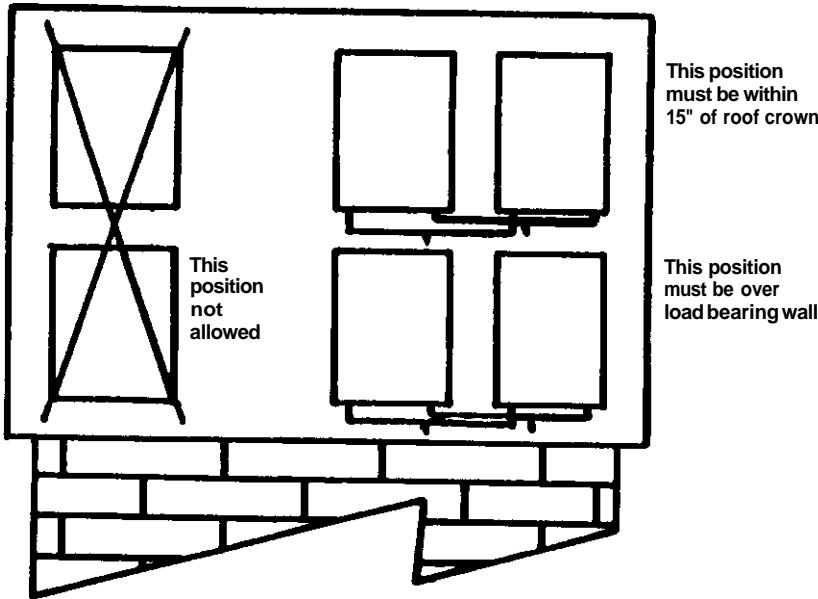

to properly distribute the weight of the two units and to install all necessary bracing to the roof.

Two unit systems on east or west facing roofs must be installed in a "sawtooth position", tilted up facing south. Never install them side by side (**see Drawing N**). The units must be spaced far enough apart so that each unit will be supported by at least four rafters or five trusses.

Another acceptable method of installing a two unit system on an east or west facing roof is to face one unit due east and one unit due west within 15" of the roof crown. The units should be installed in the normal horizontal position and plumbed in parallel. Do not "flip" the east facing unit. Plumb the supply line to the inlet connection of both units and the return line to the outlet connections of both collectors (**see Drawing P**).

Systems that require multiple collectors should be designed to operate in parallel. Each unit

should be plumbed independently into the supply and return lines or as parallel pairs so they will drain properly.

Multiple collector systems can be installed in series in non-freezing areas but, in order to drain the system, each collector must have a boiler drain at the inlet connection and a boiler drain or vacuum breaker at the outlet connection. Never plumb more than two units in series. Plumbing three or more units in series will greatly reduce

the system's efficiency (**see Drawing Q**).

Supply and return lines for multiple collector systems should be 1 1/4" diameter for systems up to four collectors, 1.5" diameter for six collectors, 2" diameter for ten collectors. For larger systems, proper engineers should be consulted.

XIV. DIRECT SYSTEMS

Direct solar systems are usually installed in low latitude areas of the world that have an abundance of sunlight. Since the solar collection day is longer and solar radiation is more intense, a ProgressivTube collector can easily produce 180° F to 200°F water. This high temperature performance, while useful, requires careful consideration.

Direct Systems should never be plumbed with PVC plastic pipe. It cannot tolerate water temperatures above 120°F. If an existing home is plumbed with PVC cold water lines, a minimum 20' length of copper pipe must be plumbed to the collector's inlet and outlet connections. CPVC can then be connected to the copper pipe. CPVC cannot tolerate water temperatures above 160°F so the 20' copper stubs may both need to

DRAWING P

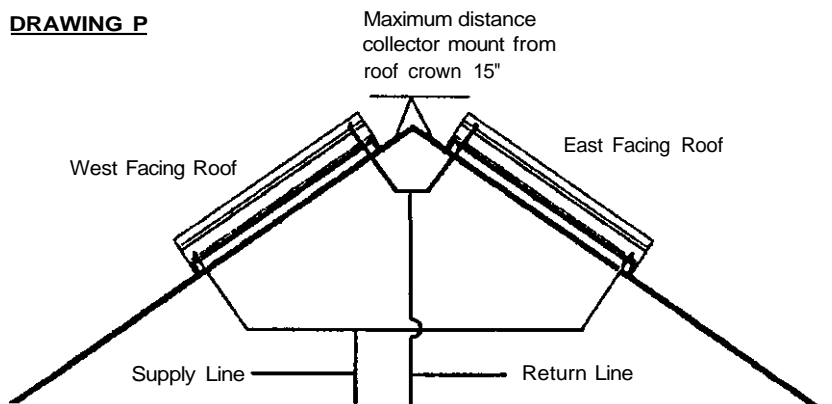

DRAWING Q

Multi Unit Installations

Series: Will Not Drain

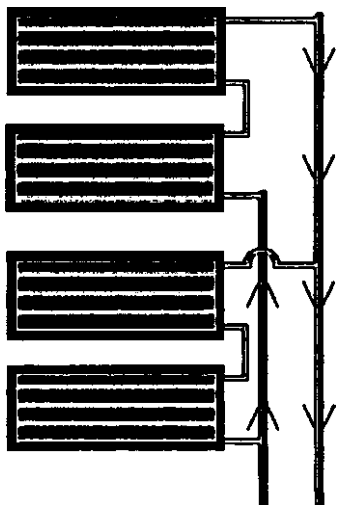

Parallel: Will Drain

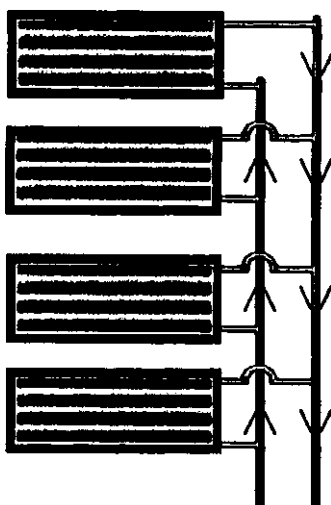

Parallel: Will Drain

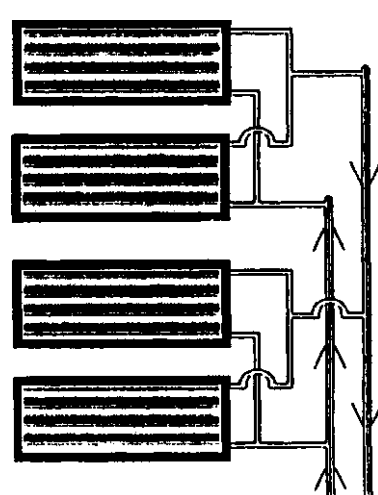

be uninsulated to allow excess heat to vent to the atmosphere. The CPVC hot water line should be as long as possible before being connected to PVC. For greater reliability, CPVC should be used for the entire hot water circuit. However, the best solution is to plumb the hot water system entirely in copper pipe.

ProgressivTube collectors work well as gravity feed systems. As long as the cold water supply is above the collector and the usage of the hot water is below the collector, the system will operate properly.

In some areas, such as the Caribbean, there is a brief period during the year in which rain and heavy cloud cover can reduce the thermal performance of the collector. This can be a problem if a large hot water demand is made on the collector in the late afternoon or evening and then another hot water demand is made early the next morning before the sun has had enough time to recharge the unit. On a clear, sunny morning in

low latitude areas, about two hours of direct sunlight is usually required to recharge a unit.

If an auxiliary backup is desired, thought should be given to installing a small electric water heater that is only enabled during inclement weather. *Detail Kin the Appendix* is a suggested schematic for plumbing this auxiliary water heater.

For new construction projects that desire an auxiliary backup but do not wish to install an electric water heater, an option is available, by custom order, of having a 4500 watt element and control relay installed in each collector. Please consult the factory for more details. This option is not available at this time for U.S. markets. All components used for the auxiliary element are UL listed.

A very inexpensive way to extend the hot water supply of a direct system is to use an anti-scald mixing valve and to install low flow, 1 gpm to 2.5 gpm, restrictors at all hot water outlets in the home.

XV. START UP PROCEDURES

1. Clean the glazing.
2. If possible, fill the collector in the morning before sun light heats up the absorber.
3. Set the flow control valves to the solar pre-heat position. Consult system valve position drawings. Close the boiler drain on the supply side of the solar loop piping. Open the boiler drain on the return side.
4. It is most important that the unit be vented to the atmosphere before and while being filled. It is recommended that the collector be filled before soldering the return piping to the collector outlet, or open the pressure relief valve or open the boiler drain on the return line, or in some other fashion make sure the unit is vented to the atmosphere. Failure to follow these instructions could void the warranty and damage the unit.

5. Open the cold water shut-off valve to fill the collector. Allow the air to be purged from the system through the open boiler drain on the return side of the solar loop piping.
6. Allow water to flow from the system for several minutes to flush out the collector and the piping.
7. Close the open boiler drain. Carefully inspect the system for leaks. Open the 2-way ball valve (#3 in the *plumbing drawings*).
8. Turn on a hot water faucet in the house to purge any remaining air from the system.
9. Set the system for normal operation by turning on the conventional water heater's heating elements. Set the thermometer to 110°F or less.
10. Set the tempering valve between 150°F and 160°F for gas systems; between 120°F and 140°F for electric systems or direct solar systems.
11. Make sure all FSEC, SRCC and manufacturer required labels are placed on the system. Consult FSEC or SRCC Appendix for required labels and their placements.
12. Give Owner's Manual and Warranty to homeowner and go over all operations of the system.

XVI. DRAIN PROCEDURES

1. Position the flow control valve in the solar by-pass mode. Consult system valve position drawings.

2. Attach hoses to both boiler drains.
3. Open both boiler drains. Make sure hoses drain the water to a proper location.
Caution: Water may be extremely hot
4. After all water has been drained from the collector, close both boiler drains and remove hoses.

The conventional water heater will continue to provide hot water to the household when the collector is by-passed and drained.

XVII. MAINTENANCE AND OPERATION

The ProgressivTube Solar Water Heating system is virtually maintenance free. However, from time to time, the glazing of the collector may need to be cleaned. The best time to clean the glass is early morning before the collector gets too hot. Use a household glass cleaner and soft cloth.

If the homeowner cannot get water to flow from the hot water lines, the problem is probably with the local water source and not the system. Check the cold water supply.

A homeowner can tell if their system is working by turning on a hot water faucet in the house and allowing it to run for several minutes. For Direct Systems, this test is very simple. If hot water comes from the faucet, the system is working. A homeowner with an FSEC approved two-way system can perform one of the following procedures to check the solar pre-heater part of the system. After letting the hot water faucet run for a few minutes, by lightly touching,

compare the temperature of the boiler drain (5B) (*see system drawings in appendix*) on the supply side of the solar loop piping with the temperature of the boiler drain (5A) on the return side. The boiler drain (5A) on the return side should feel significantly hotter than the boiler drain (5B) on the supply side. For a more precise measurement, place a bucket under the boiler drain (5A) on the return line and fill it with water after letting a hot water faucet in the house run for several minutes. Use a thermometer and compare the difference in the temperature of the water in the bucket with water coming from a cold water faucet. Both tests are best performed during the afternoon of a clear, sunny day.

For SRCC OG 300 certified three-way systems, the proper procedure for checking the system's operation is to place the system in the Solar Direct mode of operation. Turn on the hot water faucet in the household and allow the water to run. If it goes from cold to warm to hot, the system is working properly. This test is the same as for any conventional residential gas or electric water heater. For a more precise measurement follow the procedure above for comparing the temperature difference between the supply and return piping. Again, these tests are best performed during the afternoon of a clear, sunny day.

If the system is to be unused for a long period of time, such as absence due to vacation time, it is best to leave the ProgressivTube system filled with water and in the solar pre-heat mode. If unused for long periods of time during winter months in freezing climates, it is best to drain the collector and the solar loop piping.

SRCC CERTIFIED OG 300 THREE-WAY SYSTEM

SRCC SECTION:

The solar energy system described by this manual, when properly installed and maintained, meets the minimum standards established by the SRCC. This certification does not imply endorsement or warranty of this product by SRCC.

The following procedures are required for SRCC certified systems.

1. The SRCC OG 300 three-way system plumbing schematic must be followed when installing the system.
2. All standards in the SRCC OG 300 Operating Guidelines and Minimum Standards (January 1996) must be met.
3. A 40 or 50 gallon conventional electric or gas water heater must be used as a backup water heater. Direct Systems or the use of an instantaneous water heater as a backup are not SRCC certified.
4. An anti-scald valve must be used on the hot water out to the household (see plumbing schematic).
5. All piping in unheated attic spaces or exposed to outdoor weather conditions in climates where freezing might occur, must have a minimum of 1.5" of Rubatex or Armaflex pipe insulation or some other form of pipe insulation that has an R value of 10.7 or greater.
6. There must be a cold water shut off valve on the cold water inlet supply line so the hot water system can be isolated from the house cold water supply.
7. All ProgressivTube® solar water

heating systems have a freeze tolerance limit of 10°F ambient temperature. Freeze tolerance limits are based upon an assumed set of environmental conditions. Extended periods of cold weather, including ambient air temperatures above the specified limit, may cause freezing in exposed parts of the system. It is the owner's responsibility to protect the system in accordance with the Supplier's instructions if the air temperature is anticipated to approach the specified freeze tolerance limit.

8. Place the Freeze Protection sticker provided on the conventional water heater in a place that is noticeable and easy for the homeowner to read. If the sticker is lost or damaged, type a new one and tape it, with clear tape, on the tank (completely cover the label with clear tape to protect it).

Freeze Protection Information

The freeze protection method of this system is thermal mass and manual draining. In some areas an automatic freeze prevention valve may have been installed. This valve will open during freezing weather and allow a small flow of water. Drain the system as instructed in the Owner's Manual when air temperatures of 10°F or below are expected.

9. Place the "Refilling Your Collector" label on the return line boiler drain. If label is damaged or missing, type a new one on heavy paper stock and seal in clear plastic to make it waterproof. Attach the label with wire or plastic tie. Label must read as follows:

IMPORTANT

Read Before Refilling

Your Collector

If you have drained your collector, for any reason, it is most important that the collector be vented to the atmosphere during refilling. Refer to the Owner's Manual or the directions on the other side of this tag. Only potable water is to be used in this system.

Warning: Water could be discharged at high temperature and/or pressure.

Open This Valve Before Filling

Place a hose on or a bucket under this drain valve. Open this valve. The collector is now vented to the atmosphere. Fill the collector. Close this valve when water starts to flow out of it. It is strongly recommended that you refill your collector in the morning or early evening. Filling a hot, empty collector without this valve being opened, or some other means taken to vent the collector to the atmosphere, could damage your system and void the warranty.

10. Place the isolation valve label on the two-way ball valve on the return line (valve #3 in the schematic). If label is lost or damaged, type a new one on heavy paper stock and seal in clear plastic to make it waterproof. Attach the label with plastic or wire tie. The label must read as follows:

System Isolation Valve - Normally Open

11. Give homeowner a copy of the Owner's Manual, SRCC Certification Award, Warranty and local phone number of the installing contractor. Go over all operations of the system and how to obtain warranty service if needed.

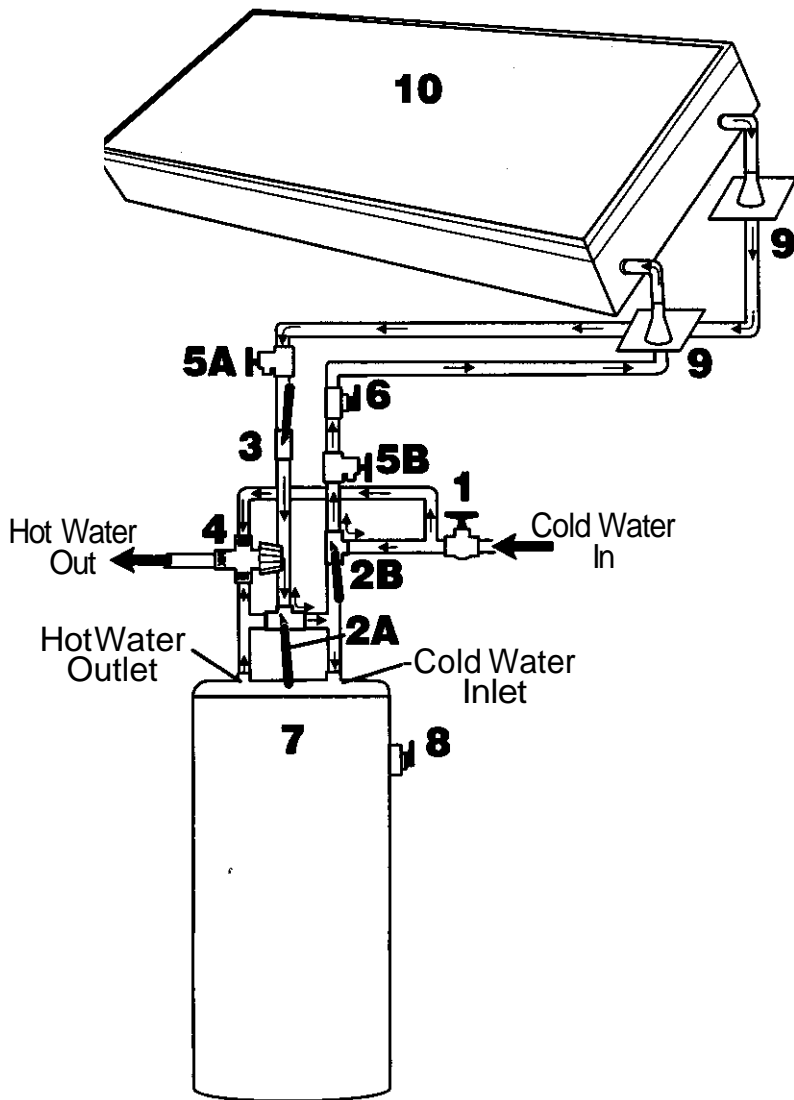

SRCC OG 300 3-WAY SYSTEM

- | | |
|---------------------------------------|---|
| 1. Supply Shut Off Valve | 6. Pressure Relief Valve:
<i>150 psi</i> |
| 2. 3-Way Ball Valve:
<i>Bronze</i> | 7. Conventional Water Heater |
| 3. 2-Way Ball Valve:
<i>Bronze</i> | 8. Temperature/Pressure Relief Valve:
<i>2 10°F/150psi</i> |
| 4. Tempering Valve | 9. Roof Jacks |
| 5. Boiler Drains:
<i>Bronze</i> | 10. ProgressivTube® |

LIMITED

TEN YEAR CONSUMER WARRANTY

THERMAL CONVERSION TECHNOLOGY

P.O. BOX, 3887 SARASOTA, FLORIDA 34230

1. WHAT IS COVERED BY THIS WARRANTY.

The ProgressivTube® Passive Solar Water Heater (Product) is warranted by Thermal Conversion Technology (the Manufacturer), to be free of defects in materials and workmanship and from damage due to freezing, corrosion, and overheating for a period of Ten years from the date of original purchase, subject to the conditions, limitations, and exclusions set forth below. This warranty applies to the original purchaser and to all subsequent owners during the warranty period.

2. WHAT IS NOT COVERED BY THIS WARRANTY.

This warranty does not apply to:

- (a) Conditions resulting from a defect in a component or part which is not part of the product or manufactured by the Manufacturer.
- (b) Conditions resulting from a significant departure from the Manufacturer's Installation and Operation Manual or Owner's Manual, including any violation of use restrictions expressed therein.
- (c) Corrosion that is caused by operating the Product with any fluid other than potable domestic water. Specifically, water must meet EPA Standards for Potable Drinking Water and have PH maintained between 7.0 and 9.0 at all times.
- (d) Conditions which result in excessive scale build-up within the Product.
- (e) Conditions which cause flow velocities in the Product to exceed 5ft/second.
- (f) Conditions resulting from failure to provide reasonable and necessary maintenance in accordance with the Owner's Manual, including failure to drain the Product in the event of outdoor air temperatures below 10° F.
- (g) Conditions resulting from any misuse, abuse, negligence, accident, disassembly, or alteration.
- (h) Normal fading and minor deterioration of exterior surfaces resulting from exposure to the elements, except for conditions that significantly affect performance.
 - (i) Breakage of glass.
 - (j) Conditions resulting from improper storage procedures before installation. Improper storage procedures may consist of but not limited to storage in any position other than horizontal with glass up and backsheet down.
- (k) Conditions resulting from improper draining or filling.

3. FIVE YEAR FULL WARRANTY.

During the first five years of the warranty period, the Manufacturer will repair the Product using either new or used parts within a reasonable time and without charge for materials, labor, or transportation. If the Manufacturer is unable to repair the Product after a reasonable number of attempts as determined by the Manufacturer, the Manufacturer will provide either a refund for the purchase price or a replacement Product at Manufacturer's option.

4. FIVE YEAR LIMITED WARRANTY.

During the remaining five years of the warranty period, the Manufacturer will repair the Product using either new or used parts within a reasonable time and without charge for materials. The purchaser of the Product will be charged for any labor and/or transportation required for an on site diagnosis and the removal, repair and reinstallation of the required material.

5. HOW TO OBTAIN WARRANTY SERVICE.

To obtain warranty service on the Product, notify the Manufacturer by telephone or letter and verify that the warranty is still in effect by giving identification of the equipment by model number and serial number, date of completion of installation, and the nature of the warranty problem. Service will be provided by the Manufacturer, or a person, dealer or distributor designated by it. This will ordinarily be the company from whom the Product was purchased.

6. LIMITATION OF OTHER WARRANTIES.

The warranty given in paragraph 1 is the exclusive express warranty on the Product and is given in place of all other warranties. No warranty of merchantability or fitness for a particular purpose shall apply. The agents, dealers and employees of the Manufacturer are not authorized to make modifications to the warranty or additional warranties that are binding on the Manufacturer. Accordingly, additional statements do not constitute warranties and should not be relied on by the purchaser. The implied warranties given by State law are limited in duration to not more than the time specified in paragraph 1 or one year, whichever is longer. Some states do not allow imitations on how long an implied warranty lasts so the above limitation may not apply to you.

7. LIMITATION OF LIABILITY FOR DAMAGES.

In any case the Manufacturer shall not be liable for special, incidental or consequential damages arising from breach of warranty, breach of contract, negligence, strict liability or any other legal theory without limitation: damages for loss of profits or revenue; loss of use of the Product or any associated equipment or property; cost of capital; cost of any substitute product, equipment, facilities or services; loss of enjoyment of the Product; or expenses caused by its inoperable condition. Some states do not allow the exclusion or limitation of incidental or consequential damages so the above limitation or exclusion may not apply to you.

8. WARRANTY RIGHTS.

This warranty gives you specific legal rights and you may also have other rights that vary from state to state.

9. THIS IS A LIMITED WARRANTY.

PROGRESSIVTUBE® SRCC OG 300 3-WAY SYSTEM

LEGEND

- | | |
|---------------------------------|-----------------------------------|
| 1. Existing cold water shut off | 4. Aquamix Anti-Scald Valve |
| 2. 3-way Ball Valve: Bronze | 5. Boiler Drains: Bronze |
| 3. 2-way Ball Valve: Bronze | 6. Pressure Relief Valve: 150 psi |

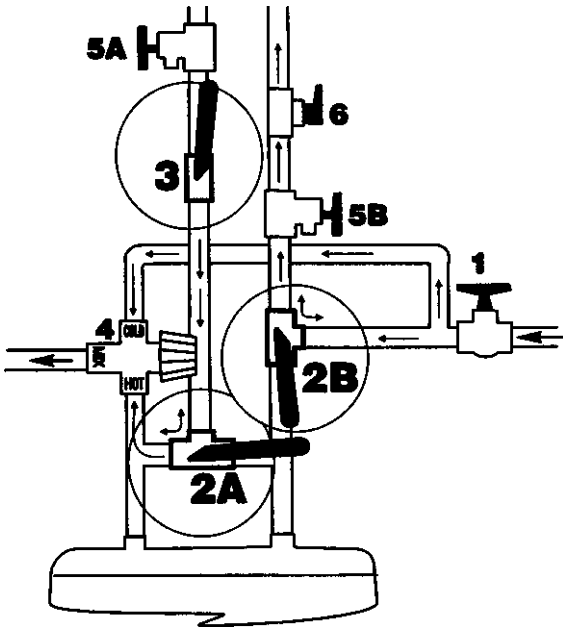

A - SOAR DIRECT

Use ONLY during Spring through Fall. For MAXIMUM SAVINGS shut off breaker to electric water heater

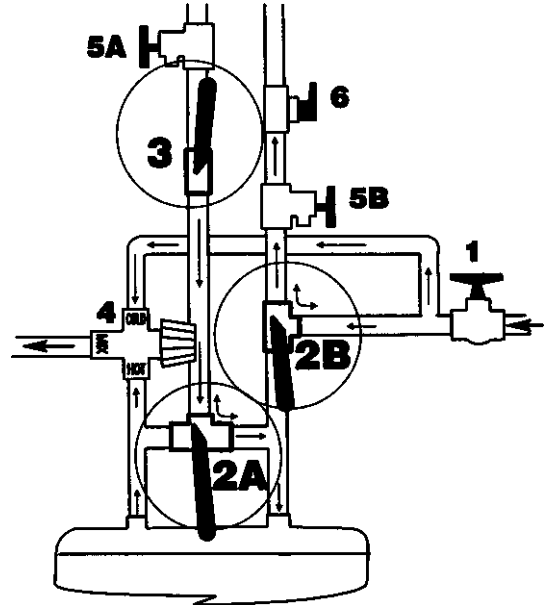

B - SOLAR PRE-HEAT

For NORMAL OPERATION - Conventional water heater also acts as backup if needed. Good for year round operation

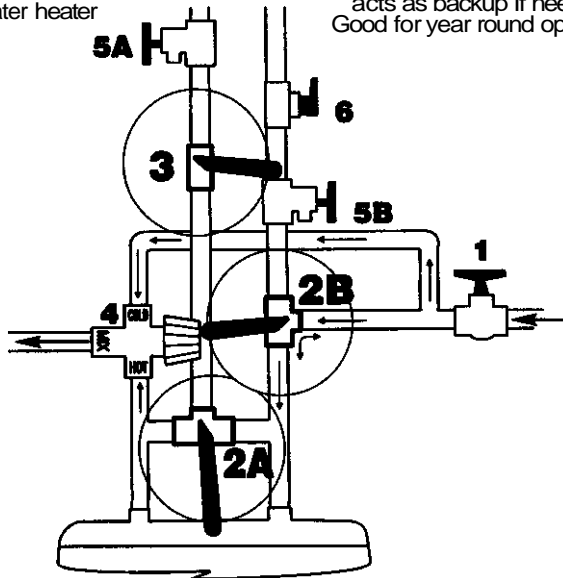

C - SOLAR BY-PASS

For severe winter operation - or other reasons for COMPLETE SOLAR SHUTDOWN

TCT010995

FSEC APPROVED 2-WAY SYSTEMS

FSEC SECTION:

The following procedures are required for FSEC approved systems.

1. The FSEC Approved Solar Energy System plumbing schematic must be followed when installing the system.
2. All standards in the FSEC-GP-7-80 must be met.
3. Place the Freeze Protection sticker provided on the conventional water heater in a place that is noticeable and easy for the homeowner to read. If the sticker is lost or damaged, type a new one and tape it, with clear tape, on the tank (completely cover the label with clear tape to protect it). Label must read as follows: (SEE LABEL A)
4. Place the "Refilling Your Collector" label on the return line boiler drain. If label is damaged or missing, type a new one on heavy paper stock and seal in clear plastic to make it waterproof. Attach the

label with wire or plastic tie. Label must read as follows: (SEE LABEL B)

5. Give homeowner a copy of the Owner's Manual, FSEC Certifications, Warranty and local phone number of the installing contractor. Go over all operations of the system and how to obtain warranty service if needed.

LABEL B:

IMPORTANT **Read Before Refilling Your** **Collector**

If you have drained your collector, for any reason, it is **most** important that the collector be vented to the atmosphere during refilling. Refer to the Owner's Manual or the directions on the other side of this tag. Only potable water is to be used in this system.

Warning: Water could be discharged at high temperature and/or pressure.

Open This Valve Before Filling

Place a hose on or a bucket under this drain valve. Open this valve. The collector is now vented to the atmosphere. Fill the collector. Close this valve when water starts to flow out of it. It is strongly recommended that you refill your collector in the morning or early evening. Filling a hot, empty collector without this valve being opened, or some other means taken to vent the collector to the atmosphere, could damage your system and void the warranty.

LABEL A:

Freeze Protection Information

The freeze protection method of this system is thermal mass and manual draining. In some areas an automatic freeze prevention valve may have been installed. This valve will open during freezing weather and allow a small flow of water. Drain the system as instructed in the Owner's Manual when air temperatures of 10°F or below are expected.

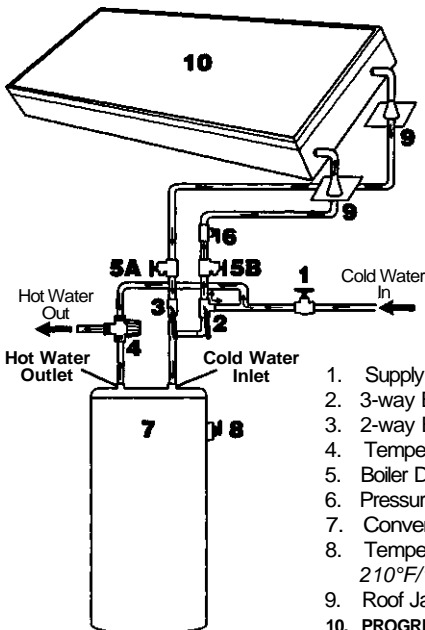

**2-WAY SYSTEM
FOR ELECTRIC WATER HEATERS**

1. Supply shut off valve
2. 3-way Ball Valve: *Bronze*
3. 2-way Ball Valve: *Bronze*
4. Tempering Valve
5. Boiler Drains: *Bronze*
6. Pressure Relief Valve: *150 psi*
7. Conventional Water Heater
8. Temperature/Pressure Relief Valve: *210°F/150psi*
9. Roof Jacks
10. PROGRESSIVTUBE®

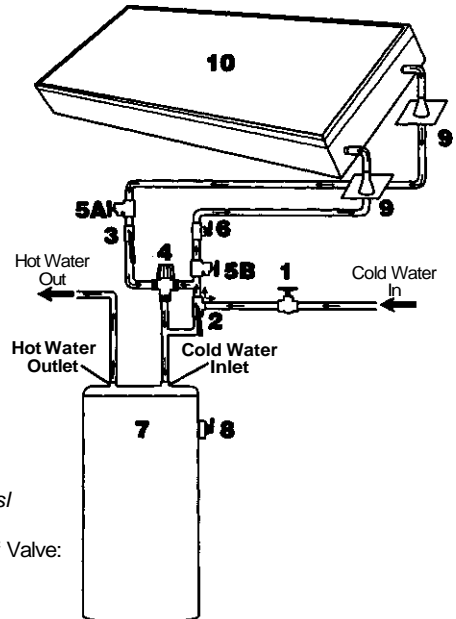

**2-WAY SYSTEM
FOR GAS WATER HEATERS**

ELECTRIC 2-WAY SYSTEM

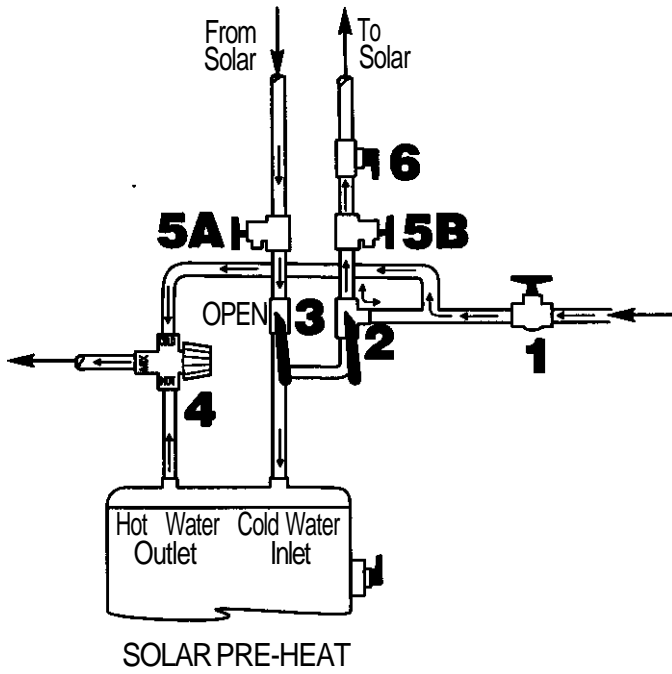

GAS 2-WAY SYSTEM

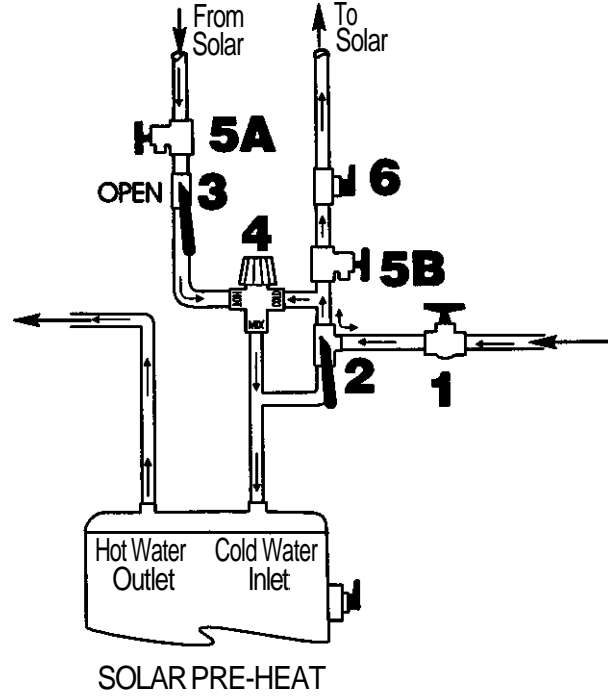

LEGEND

- | | |
|------------------------------------|--|
| 1. Existing cold water shut-off | 4. Aquamix Anti-Scald Valve |
| 2. 3-way Ball Valve: <i>Bronze</i> | 5. Boiler Drains: <i>Bronze</i> |
| 3. 2-way Ball Valve: <i>Bronze</i> | 6. Pressure Relief Valve: 150 <i>psi</i> |

ELECTRIC 2-WAY SYSTEM

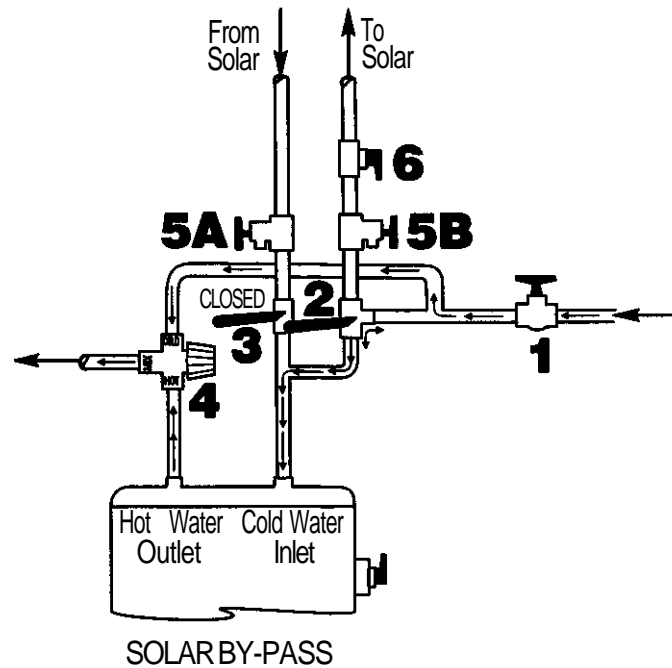

GAS 2-WAY SYSTEM

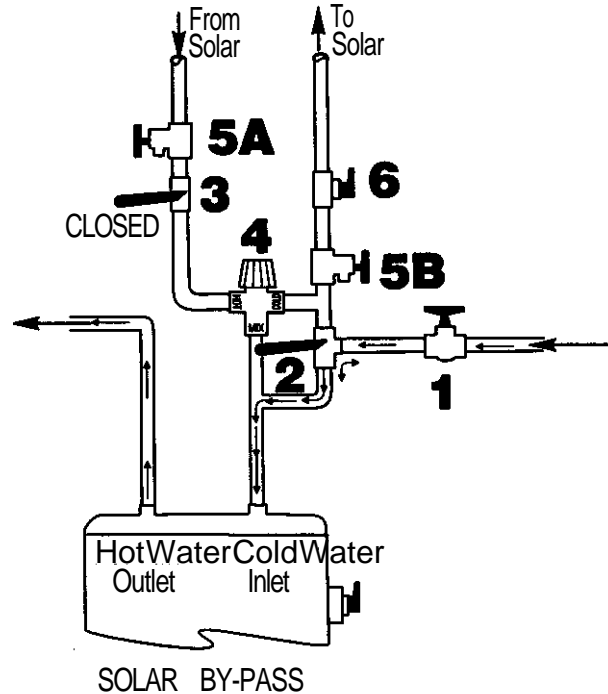

INSTALLATION DETAILS

DETAIL A SPACER BLOCK WITH SPANNER MOUNT Good For All Roof Mount Positions

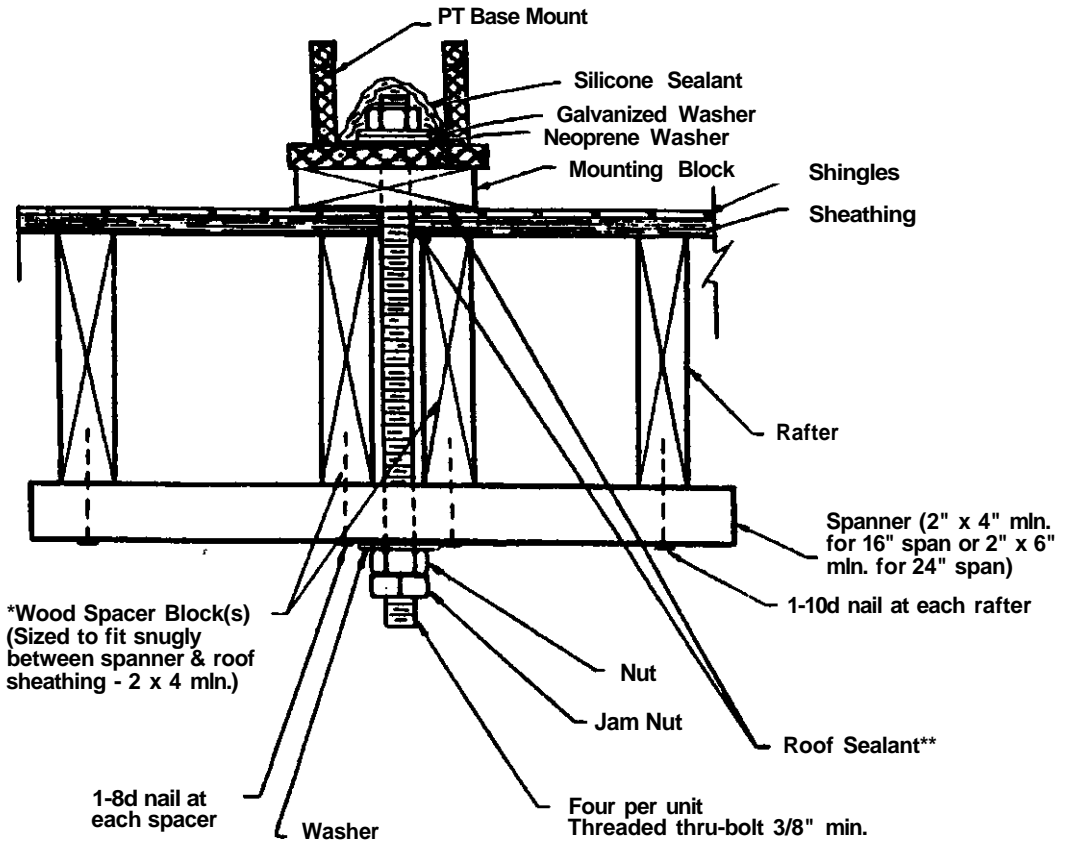

*Spacer Block(s)

1. Spacer blocks should be installed within 1 inch of the thru-bolt.
2. When bolt is within 2" of a rafter only one spacer block will be required on the opposite side of the bolt, away from the rafter.
3. Two spacer blocks are required when the bolt is more than 2" from the rafter.

4. When the mounting clips of adjacent collectors are installed side by side and the thru-bolts are 1.5" or more apart, it will be necessary to have at least one spacer block (or rafter) between bolts.

** **Roof Sealant** - Required between mounting block and shingles/sheathing. Bolt holes shall be sealed to prevent moisture penetration.

Mounting Blocks

This drawing shows the use of a mounting block to provide the water tight seal between the mounting hardware and the roof. Metal flashing sheets or J-Brackets can be used instead of the mounting blocks

DETAIL B
LAG BOLT MOUNTING
Good For All Roof Mount Positions

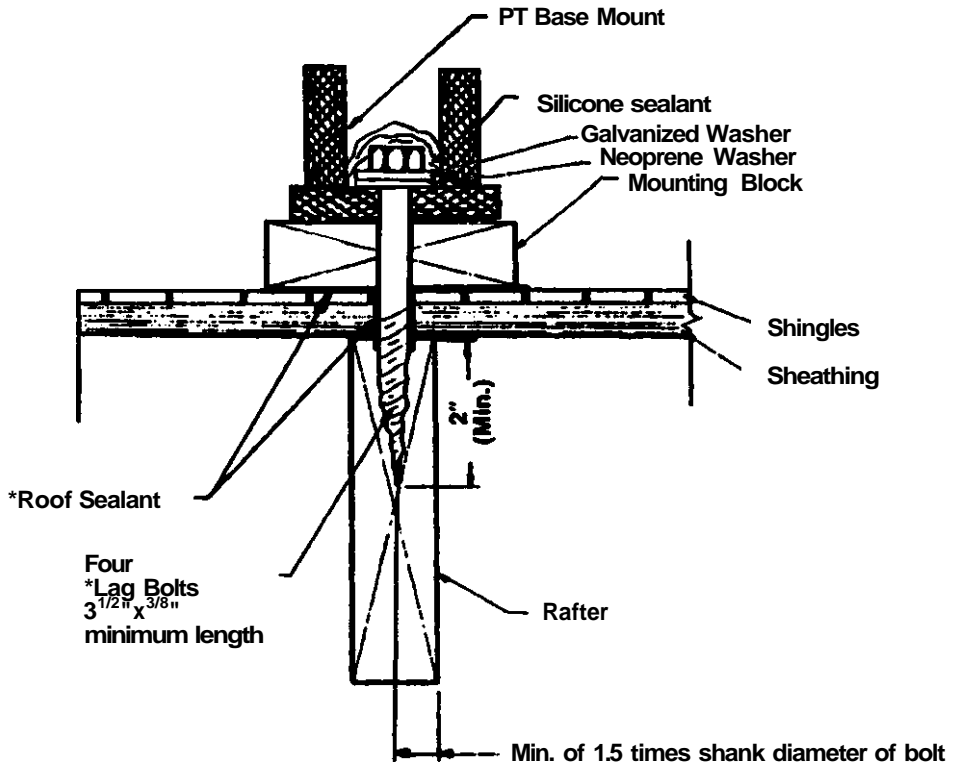

***Lead Holes Required -**
 Predrill lead holes for the shank at 100% of the shank diameter. Lead holes for the threads at 60-75% of the shank diameter.

**** Roof Sealant -** Required between mounting block to and shingles/sheathing. Bolt holes shall be sealed to prevent moisture penetration. Fill bolt hole with sealant prior to inserting bolt.

Mounting Blocks
 This drawing shows the use of a mounting block to provide the water tight seal between the mounting hardware and the roof. Metal flashing sheets or J-Brackets can be used instead of the mounting blocks

DETAIL C

PITCH POCKET METHOD

Good For All Roof Mount Positions

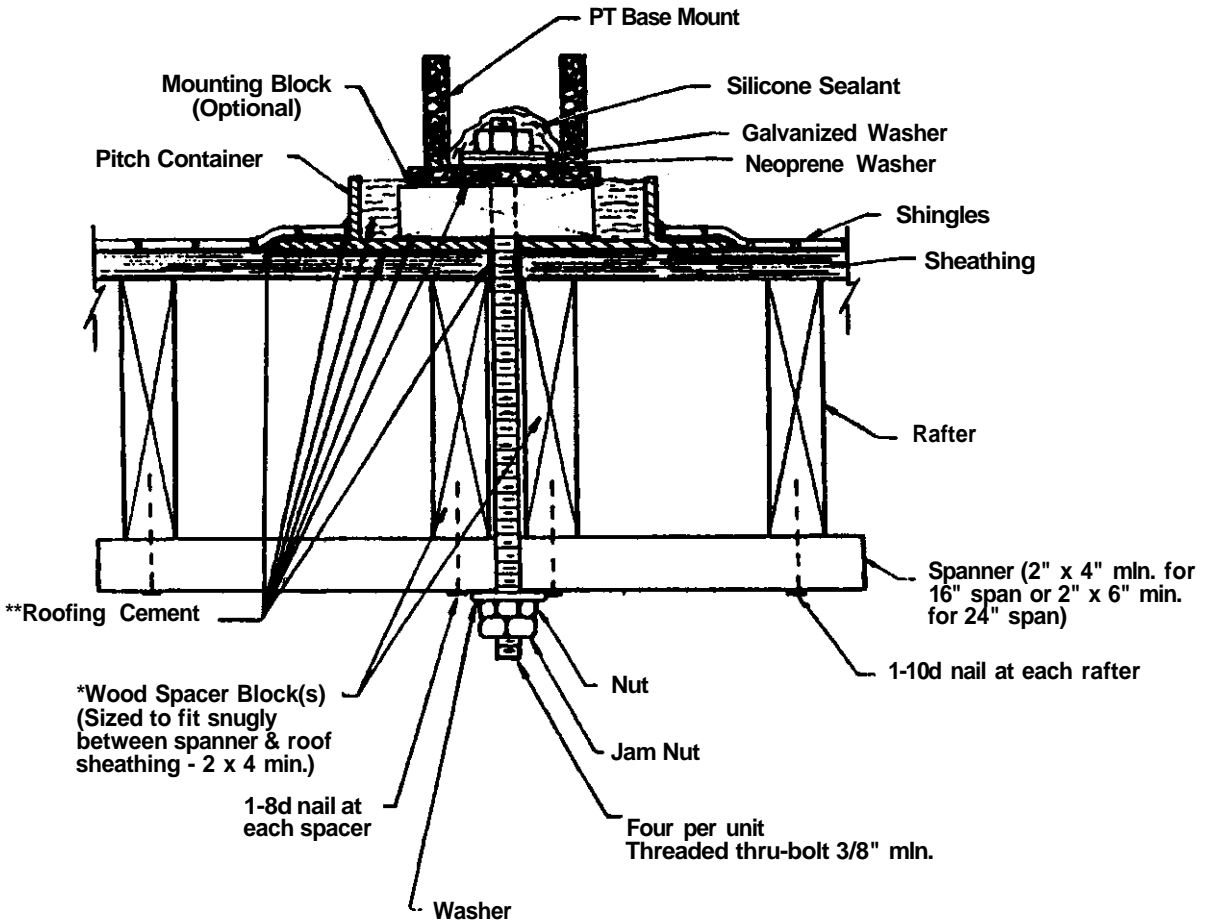

***Spacer Block(s)**

1. Spacer blocks should be installed within 1 inch of the thru-bolt.
2. When bolt is within 2" of a rafter only one spacer block will be required on the opposite side of the bolt, away from the rafter.
3. Two spacer blocks are required when the bolt is more than 2" from the rafter.

4. When the mounting clips of adjacent collectors are installed side by side and the thru-bolts are 1.5" or more apart, it will be necessary to have at least one spacer block (or rafter) between bolts.

**** Roof Sealant** - Required between pitch container and shingles/sheathing and between surfaces of mounting block and pitch container and mounting block and mounting angle. Bolt

holes shall be sealed to prevent moisture penetration.

Mounting Blocks

This drawing shows the use of a mounting block to provide the water tight seal between the mounting hardware and the roof. Metal flashing sheets or J-Brackets can be used instead of the mounting blocks

DETAIL D
J-BOLT MOUNT
Good For All Roof Mount Positions

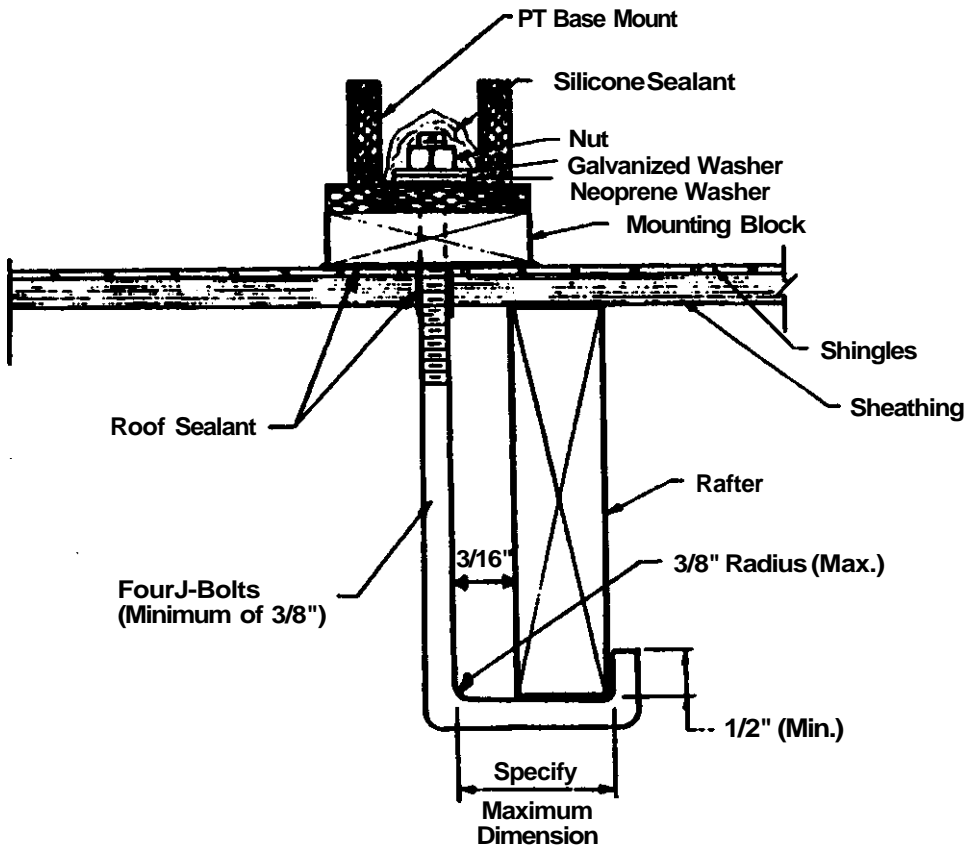

NOTE:

1. The bent portion of the J-Bolt shall not be threaded.
2. Roof Sealant is required between mounting block and shingles/sheathing. Bolt holes shall be sealed to prevent moisture penetration.

Mounting Blocks

This drawing shows the use of a mounting block to provide the water tight seal between the mounting hardware and the roof. Metal flashing sheets or J-Brackets can be used instead of the mounting blocks

DETAIL E
CATHEDRAL CEILING
Good For All Roof Mount Positions

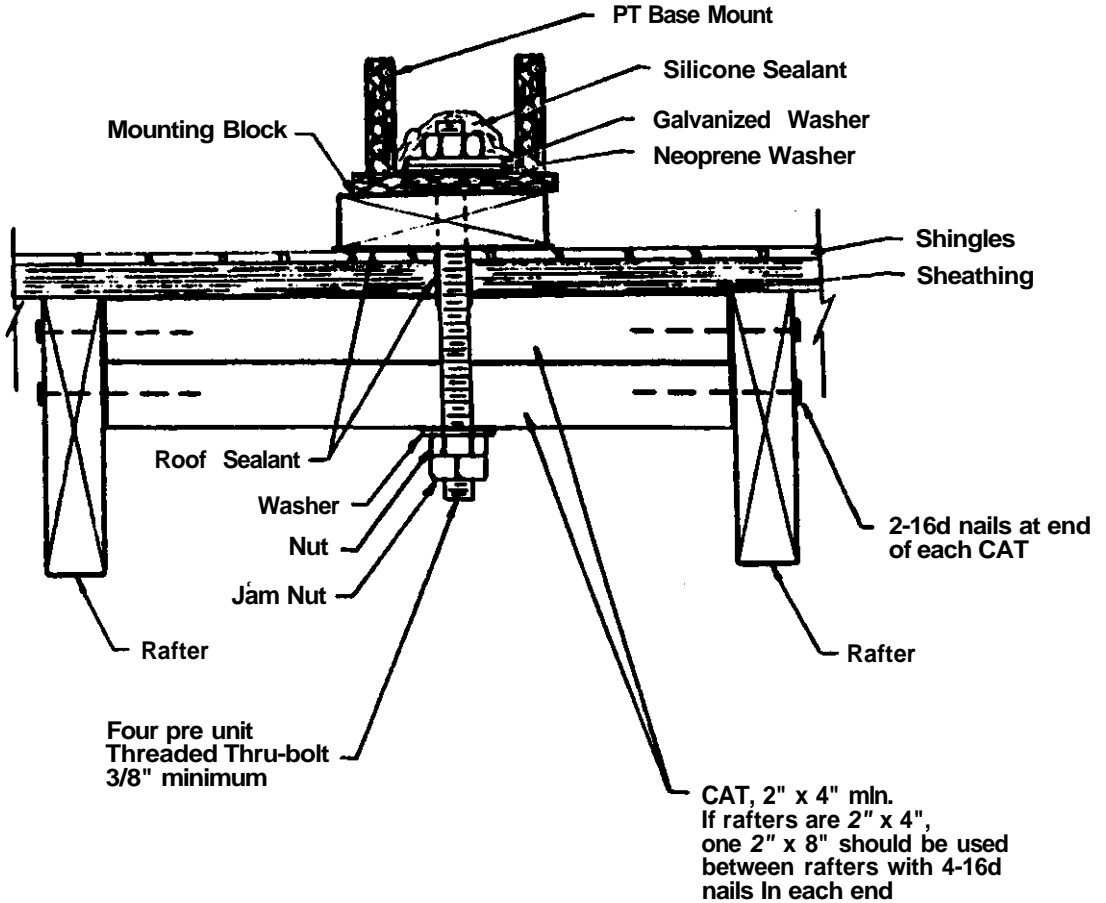

NOTE:
 CAT(s) must fit tight between rafters.

Mounting Blocks

This drawing shows the use of a mounting block to provide the water tight seal between the mounting hardware and the roof. Metal flashing sheets or J-Brackets can be used instead of the mounting blocks

DETAIL F TILE ROOF MOUNT

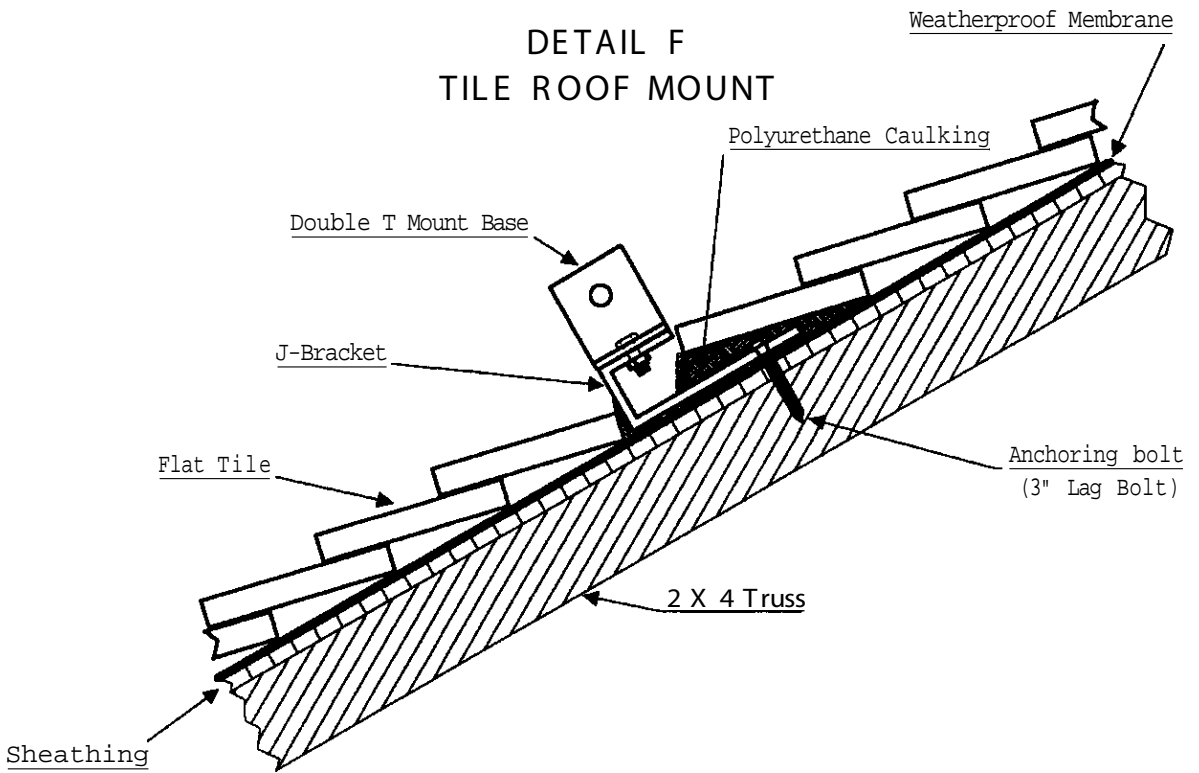

DETAIL G EXTRA TANK INSULATION

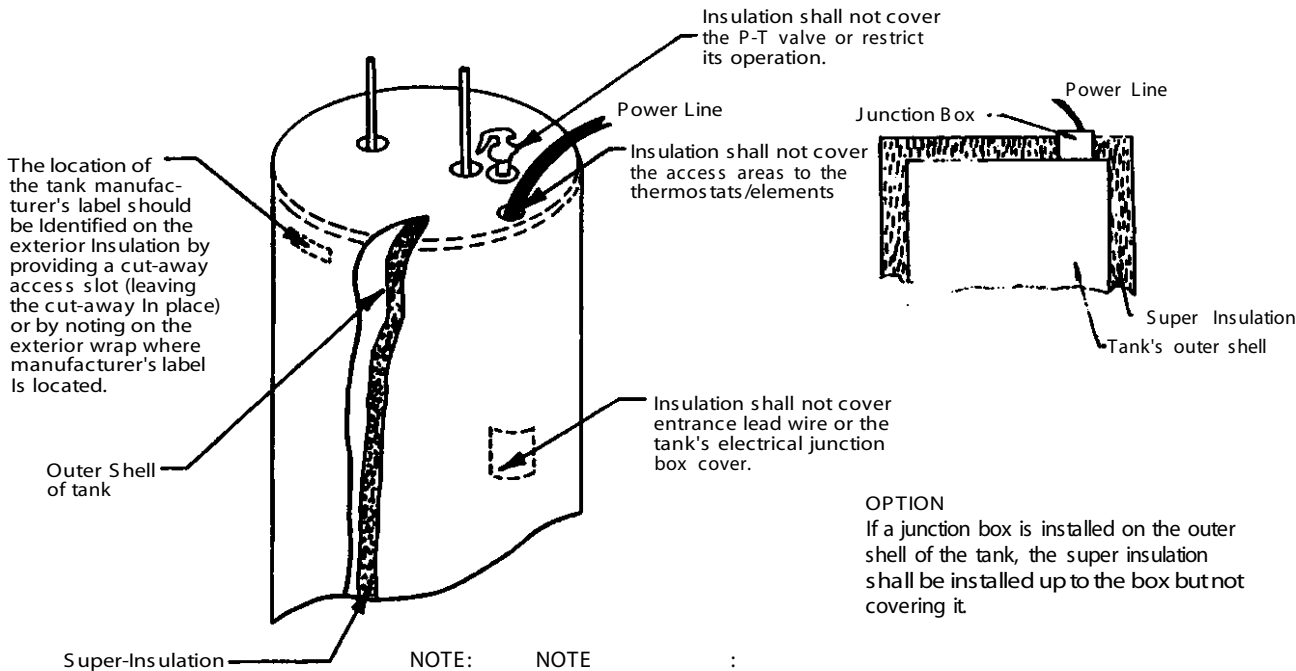

NOTE: NOTE :

1. Tanks shall be completely wrapped using an insulation blanket with a vapor barrier and with cutaway sections as shown above.
2. Interior wiring must be rated for the expected temperatures.
3. Power line (service wiring) shall be rated equal to or greater than #10 AWG type NM cable. (Assumes 4500 watt element(s) in electric water heater.)
4. Thermostat set point shall not exceed 120° F.

**DETAIL H
FLUSH TILE ROOF MOUNT**

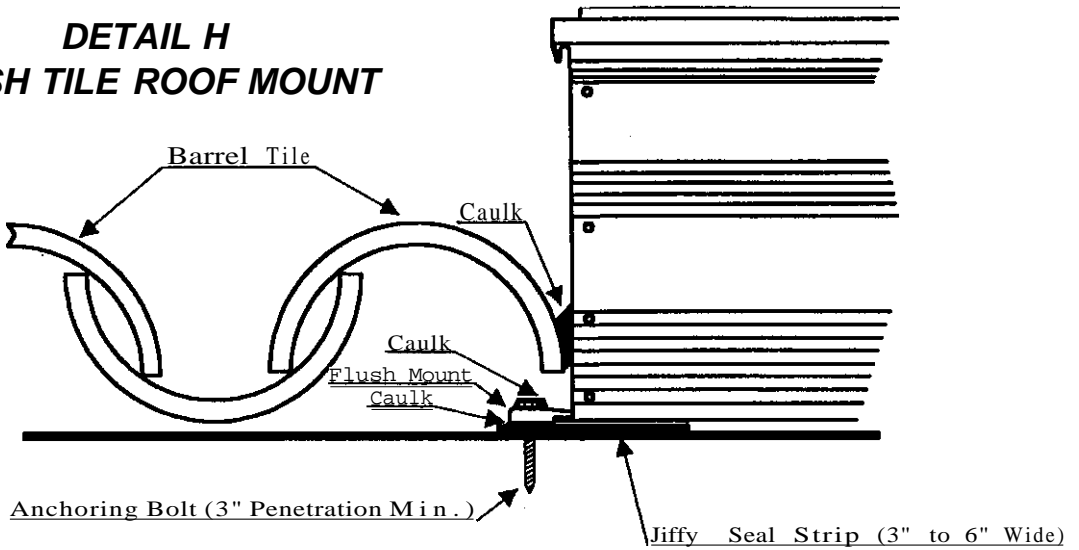

**DETAIL I
WATERTIGHT SEAL**

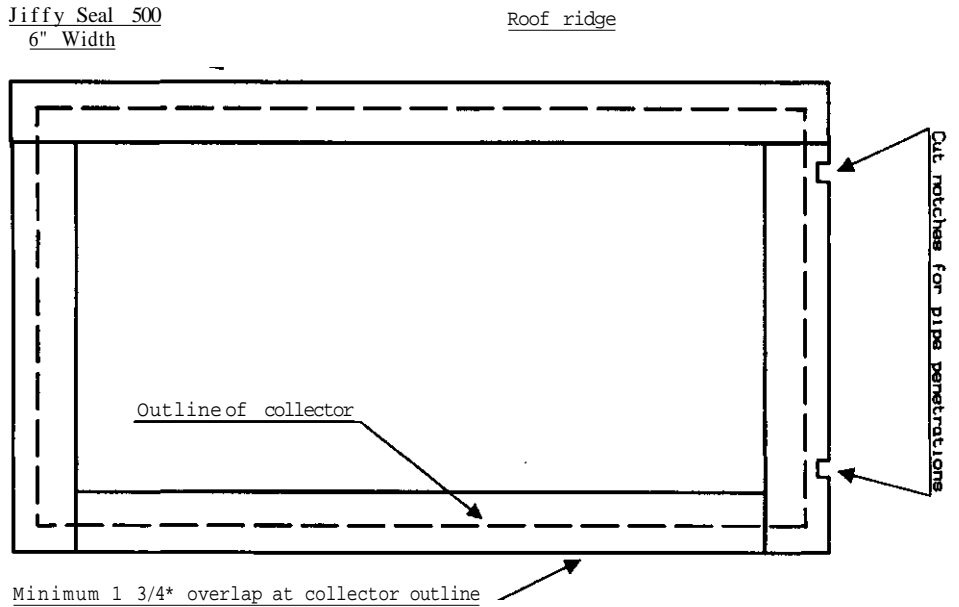

**DETAIL J
FLUSH PIPE PENETRATION**

The following technique is used when it is desirable to have the inlet and outlet piping as close to the collector as possible. It is usually used when the collector is installed flush to a roof, as in tile roof installations.

Sweat a 3/4" copper 90° short radius ell directly onto the inlet and outlet connections of the collector. Protect the collector's rubber pipe grommets from the soldering torch flame and heat with a wet rag or some other heat shield device. The roof jack flashing for the pipe might have to be trimmed so as not to interfere with the collector and its watertight sealing strip.

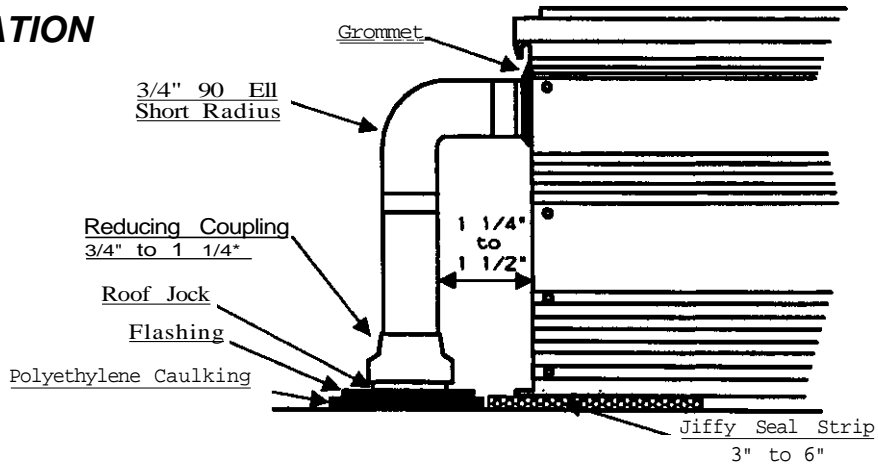

DETAIL K SOLAR DIRECT WITH BACK-UP

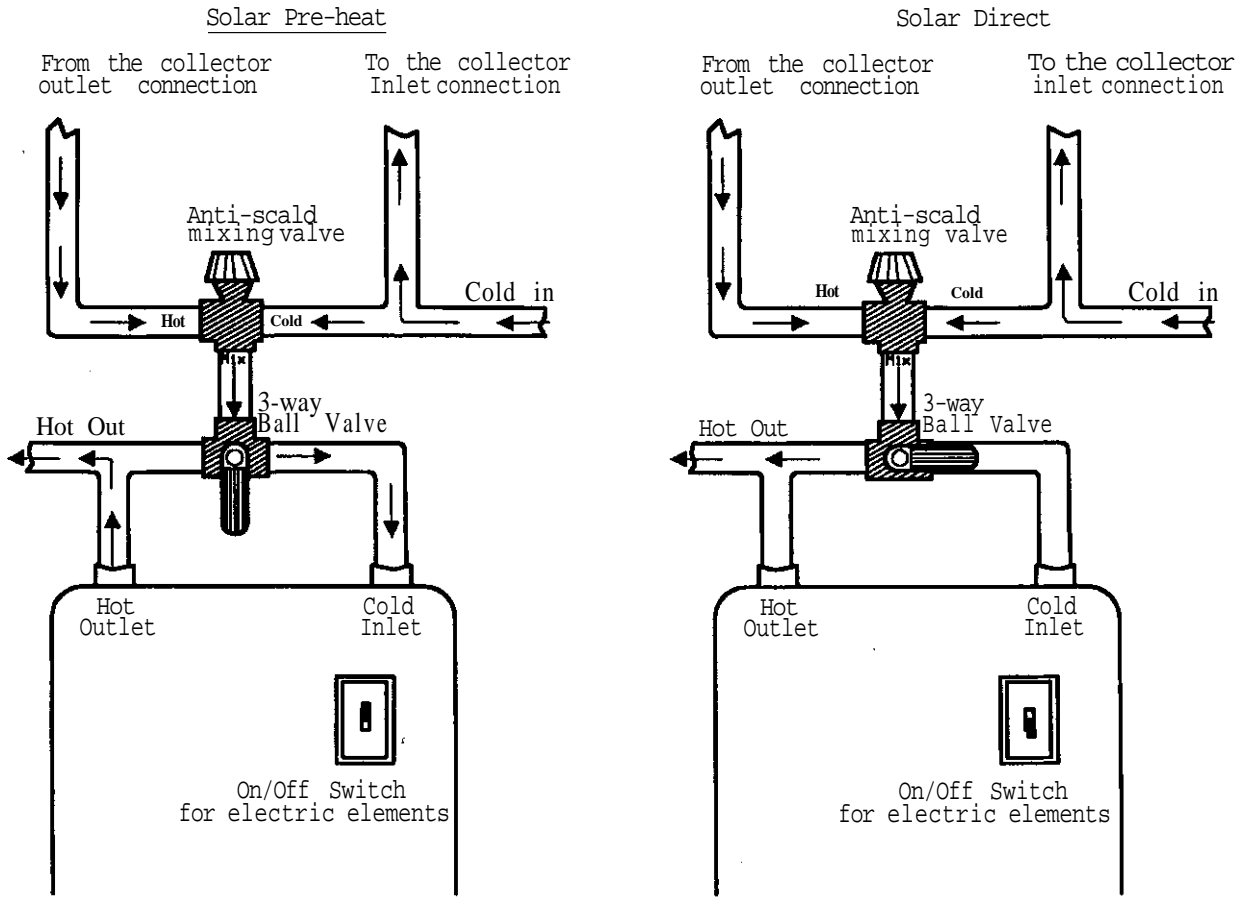

DETAIL L INSTRUCTIONS FOR REPAIRING A TANK LEAK

In the unlikely event that a leak should develop in a ProvestivTube collector, the instructions below should be followed to ensure a successful repair. Consult the factory if the leak is believed to be caused by a defect in the unit.

- 1) Repairs should be performed in the morning hours before the tank can be heated by the sun. It is best to pick a morning when there is no wind to interfere with the removal of the glass or the inner glazing layer of Teflon film.
- 2) Drain the unit and disconnect the supply and return piping from the inlet and outlet connections.
- 3) Remove the screws in the glass glazing cap strips on the top of the collector.
- 4) Carefully lift the glass out of the unit with the gasket still in place around the glass. If the gasket slips off the glass, simply push it back into place. Place the glass in a secure location so it will not be damaged.
- 5) Using an 1/8" drill bit, drill out the four #48 aluminum rivets that hold the Teflon film frame in place. Be careful of the Teflon, it is only 1 mil thick and can be easily punctured. Carefully lift out the Teflon frame and place in a secure location. Caution: even a slight breeze can turn the frame into a sail.
- 6) Remove the stainless steel rod that crosses over the top of the tank securing the two framewalls together. This rod is part of the unit's high wind load reinforcement.
- 7) The tank can now be removed by lifting up the end opposite of the inlet and outlet connections and pulling it until the inlet/outlet connections clear the insulation inside the frame. Be careful not to scratch the black finish of the tank.
- 8) Locate the leak and repair it using 95/5 solder or equal. Cover the leak area with a generous amount of solder.
- 9) Replace the tank by pushing the inlet and outlet connections through the holes in the insulation and out the frame. Allow the tank to drop into place.
- 10) Re-attach the stainless steel rod. It may be helpful to push in on the center of the frame until the locknut has been secured to the rod. Do not over tighten or the glass will not fit into place.
- 11) Replace the Teflon film frame and rivet it into place. If rivets are not available, use #8 self threading screws.
- 12) Replace the glass and its gasket. Make sure it fits evenly all the way around the frame.
- 13) Replace the glass caps. Apply pressure on the screws when tightening to ensure good compression on the gasket. This will make a good water tight seal.
- 14) Re-attach the supply and return piping.

TYPICAL ROOF BRACING

The following drawings are suggested techniques for roof structure bracing. These are not engineer certified drawings and all suggested bracing in these drawings are intended to be used with structurally sound roofs. Individual installations may require additional bracing. The contractor should follow acceptable carpentry and construction techniques if additional measures are needed. If the contractor has any questions or concerns then a structural engineer should be consulted.

TYPICAL ROOF BRACING FOR 24" SPACED RAFTERS

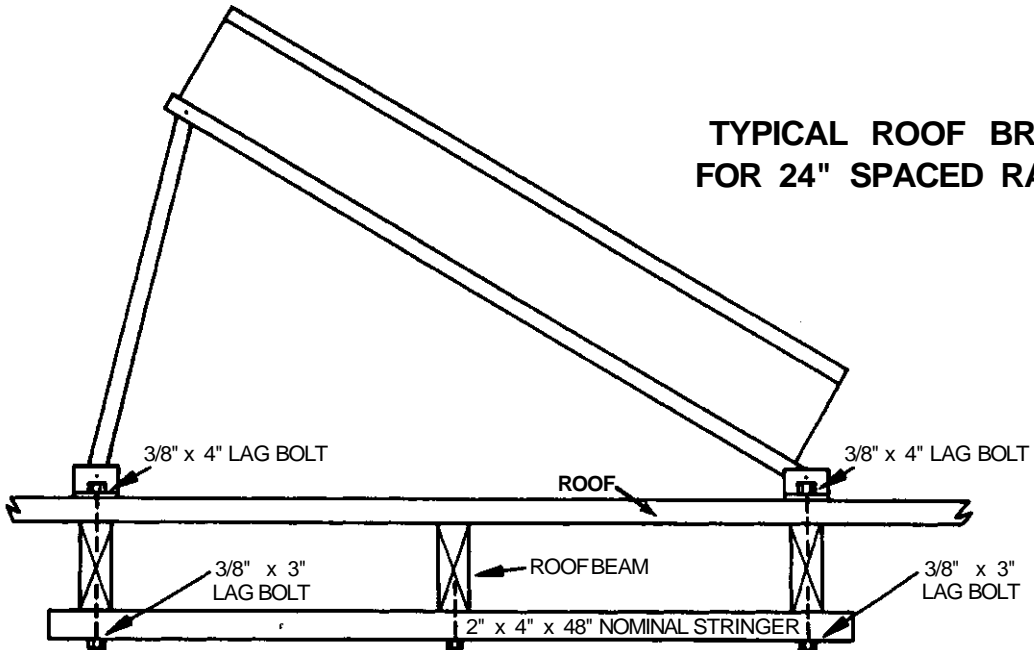

SIDE VIEW - MOUNT PARALLEL TO RAFTERS

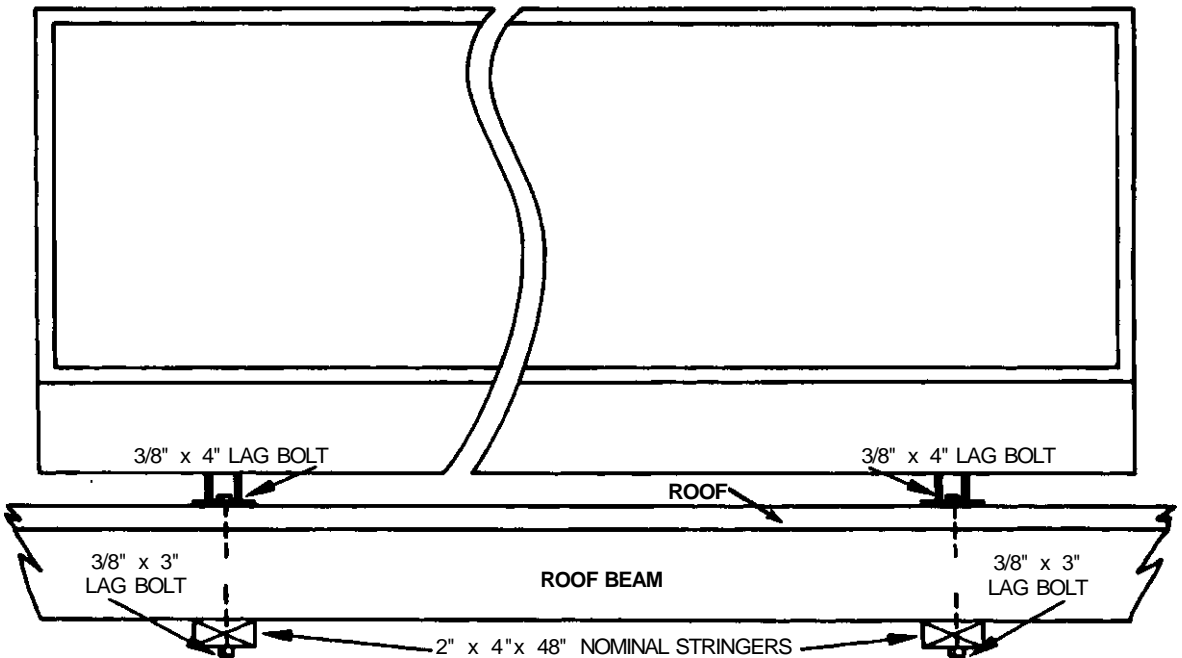

FRONT VIEW

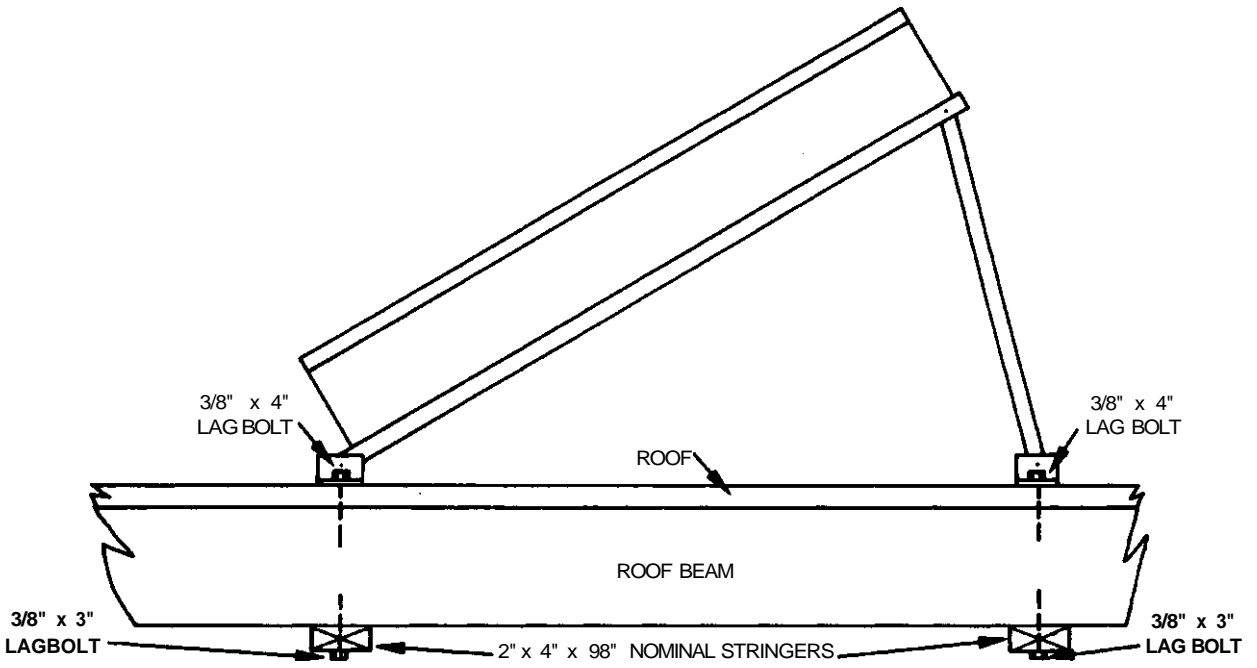

SIDE VIEW - MOUNT PERPENDICULAR TO RAFTERS

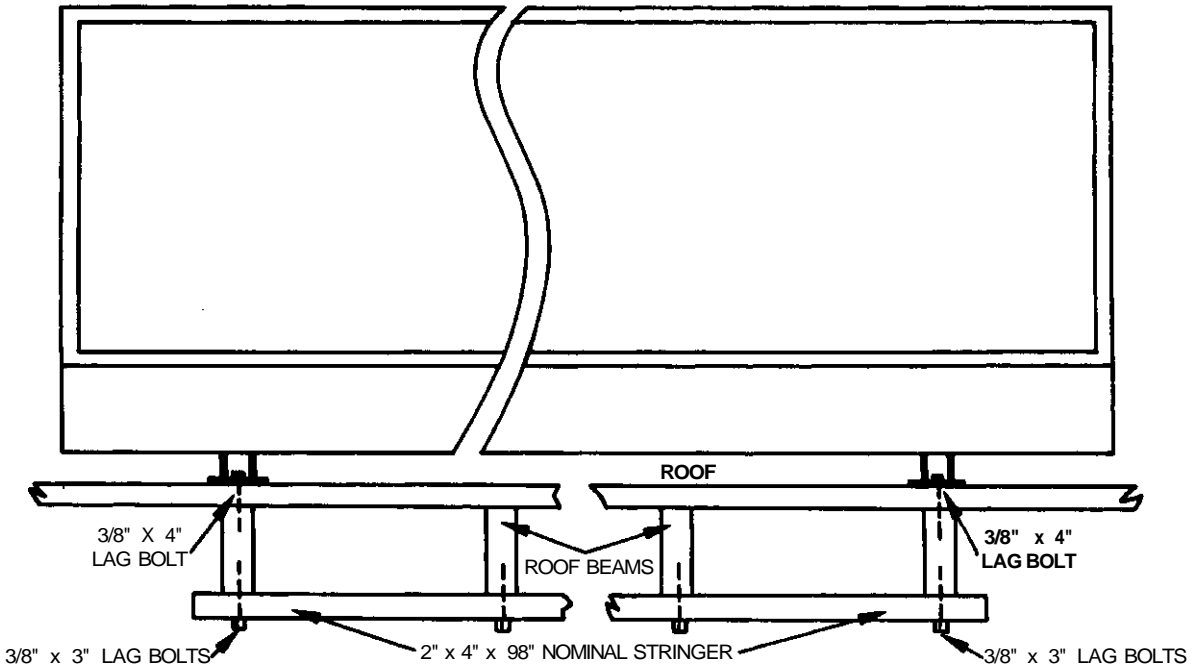

FRONT VIEW

SUGGESTED ROOF BRACING FOR CATHEDRAL CEILINGS AND OTHER WIDE RAFTER SPANS

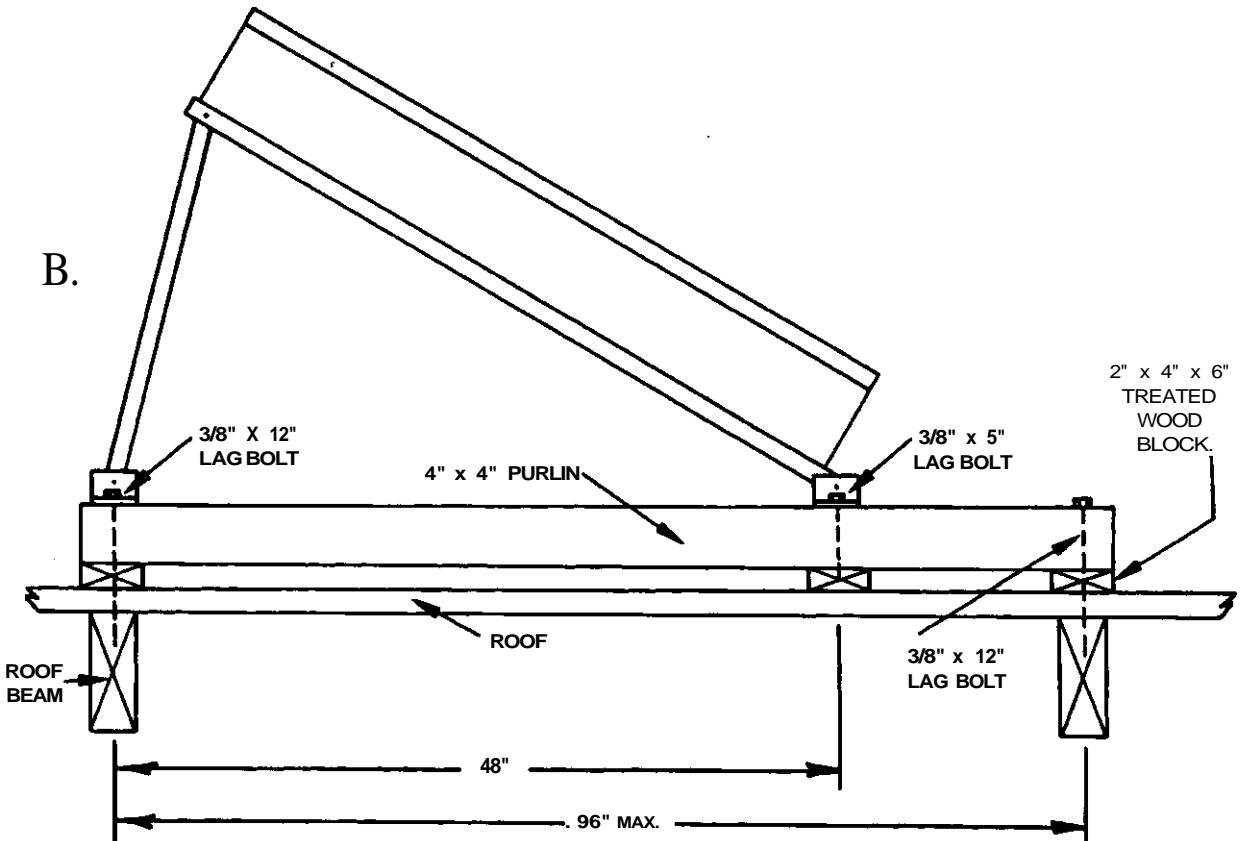
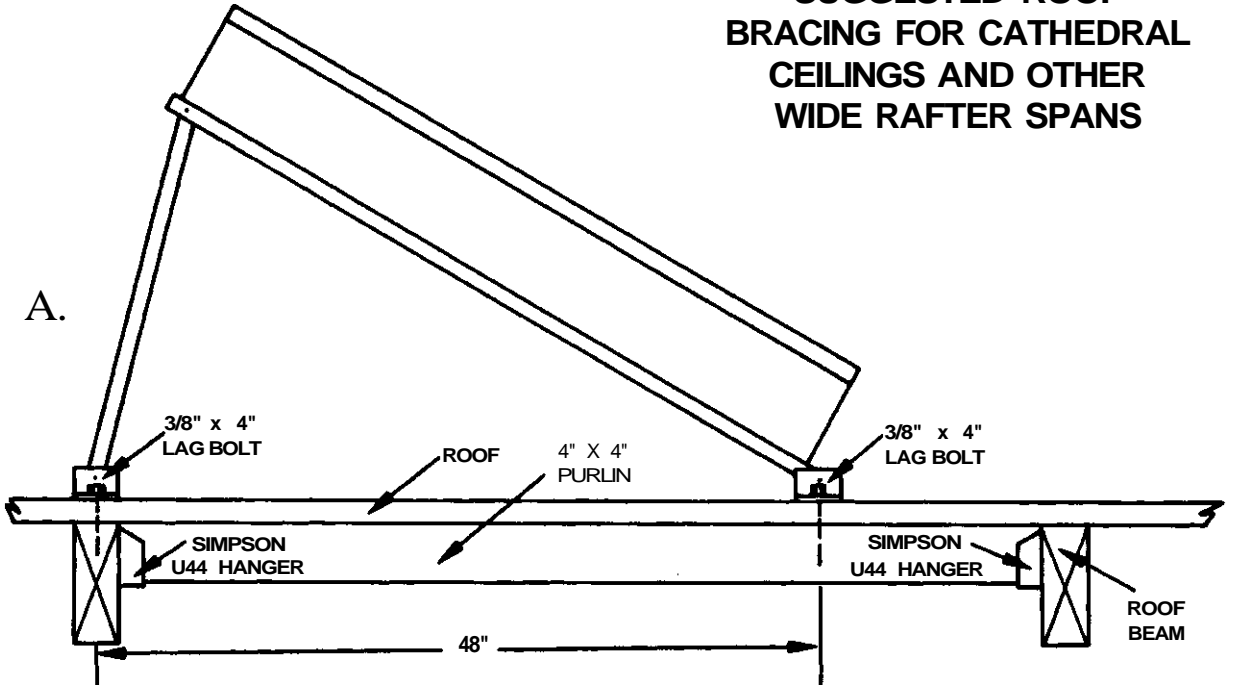



Address: 101 Copeland St. Jacksonville, FL 32204
Fax Line: 904-358-3728
Telephone: 904 - 358 - 3720